



GenRad

Handbook of Stroboscopy





GenRad

Handbook of Stroboscopy

by Frederick Van Veen

Price: \$3.00

©Copyright 1977, GenRad, Inc.
Concord, Massachusetts, U.S.A.
Form 5301-8113-E
Printed in U.S.A.



**THE HANDBOOK
OF HIGH-SPEED
PHOTOGRAPHY**

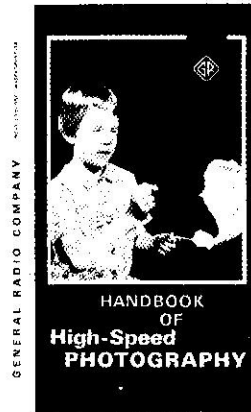

The second edition of the Handbook of High-Speed Photography is now available. The handbook features 92 pages of updated information including a new section on stroboscopic high-speed motion-picture photography. Other sections of the handbook describe methods and equipment used to synchronize flash and subject motion, techniques of multiframe photography, the use of flash-delay and photo-electric triggering devices, exposure data, lighting techniques, shadowgraph photography, exposure tables, etc.

For your copy, send \$1.50 to: GenRad, Concord, Massachusetts 01742.

Table of Contents

PREFACE	v
Chapter 1 The Stroboscope	1
1.1 Principles of Stroboscopy	1
1.2 History of the Stroboscope	3
Chapter 2 GenRad Stroboscopes and Their Accessories	7
2.1 The General-Purpose Stroboscope	7
2.2 The Battery-Operated High-Speed Stroboscope	9
2.3 The Slave Stroboscope	10
2.4 The High-Intensity Stroboscope	10
2.5 Strobolume Control Units	11
2.6 Inexpensive Inspection Strobes	12
2.7 Photoelectric Synchronizers/Contactors	13
2.8 Flash-Delay Unit	15
2.9 Surface Speed Wheels	16
Chapter 3 The Stroboscope as a Tachometer	17
3.1 General Principles	17
3.2 Fundamental Speed Measurement	17
3.3 Accuracy of Measurement	18
3.4 Range Extension by Harmonic Techniques	19
3.5 The Measurement of Mechanical Slip	22
3.6 Linear Speed Measurement	23
3.7 Calibration of Flashing Rate	24
3.8 Precision Readouts	28
Chapter 4 Slow-Motion and Stopped-Motion Observation with the Stroboscope	29
4.1 The Stroboscopic Illusion	29
4.2 Stopped-Motion Observation	29
4.3 Use of Contactors	30
4.4 Slow-Motion Observation	33
Chapter 5 High-Speed Photography	35
5.1 Introduction	35
5.2 Stopping Motion for the Camera	35
5.3 Synchronizing Flash with Motion	36
5.4 Shutter Synchronization	37
5.5 Characteristics of the Stroboscopic Flash	39
5.6 Multiple-Image Photographs	40
5.7 Exposure Data	40
Chapter 6 Applications	43
Appendixes	77
A Nomographs for Use in High-Speed Measurements	77
B Bibliography	80
C Glossary of Terms Used in Stroboscopy	82
D Catalog Section	84
Index	93

Preface

Much of the history of human invention has to do with the extension of man's senses. Man wanted to communicate farther than his voice and ears would allow, so he invented radio; he wanted to see beyond the limits of his natural vision, so he invented the telescope and the microscope; and when he designed fast-moving machines that were too fast for his eyes to follow, he gave himself slow-motion vision by means of the stroboscope.

Everybody knows what a microscope and telescope are, but the stroboscope has now gained the widespread popularity it deserves. There is no escaping the fact that the invention of the stroboscope marks one of the great industrial advances of the century. To the user of the stroboscope, nothing goes too fast to be seen or photographed. Under the light of the stroboscope, the wing-beats of a hummingbird are transformed into the lazy flappings of a crow, a high-speed dentist's drill rolls at the rate of a cement mixer, and a speeding rifle bullet is prey for the simplest camera. Propeller blades, textile looms, electric razors, piston engines — the light of the stroboscope snaps them all into low gear, where every detail of their motion can be seen, analyzed, and photographed.

This handbook attempts to bring together hundreds of stroboscopic techniques developed over forty years and collected by a company pre-eminent in the design and manufacture of stroboscopes. Future editions, it is hoped, will grow in usefulness as readers take advantage of this medium to share with all of us their adventures in stroboscopy



The Stroboscope

1.1 PRINCIPLES OF STROBOSCOPY

A stroboscope is a device that permits intermittent observation of a cyclically moving object in such a way as to produce an optical illusion of stopped or slowed motion. The stroboscope is in some respects like a movie camera. The camera shutter, operating at very high speed, chops up the action into a series of very small elements in which movement is not apparent in any one element. The film can then be projected at any desired speed, recreating the original motion at a rate faster than, slower than, or equal to the original motion. The series of projected frames takes on the appearance of continuous, rather than interrupted, motion because of what is known as persistence of vision — the ability of the human eye to hold each image for a fraction of a second, thus filling in the gaps between frames. The enjoyment of movies and the optical illusions of stroboscopy depend to a great extent on persistence of vision.

A movie-camera shutter can produce a stroboscopic effect if it is at or near synchronism with some cyclic motion. If, because of the chopping action of a camera shutter, we are allowed momentary glimpses of a spinning wagon wheel exactly 200 times a minute, and if that wheel is spinning at the rate of 200 revolutions a minute, then at each glimpse of the wagon wheel, it will be in the same position. Since the camera shutter never allows us to see the wheel in any other position, it appears to stand still. If the camera speed is advanced so that we are now given, say, 205 frames a minute, then each frame occurs $1/205$ of a minute later than the previous frame. However, the wheel needs more time ($1/200$ of a minute) to return to a given position, so that each successive picture catches the wheel at a slightly earlier part of its cycle. The effect, not uncommon in motion pictures, is that the wheel appears to rotate very slowly backwards. If we slow down the camera speed to 190 frames a minute, each frame captures the wheel at a slightly later part of its cycle, and the wheel appears to rotate slowly forward. Thus, by controlling the rate at which we interrupt vision, we can produce a replica of the high-speed motion at almost any slow speed we desire, forward or backward. Intermittency of observation can be provided by mechanical interruption of the line of sight (as with the motion picture camera) or by intermittent illumination of the object being viewed. The modern industrial stroboscope is basically a lamp plus the electronic circuits necessary to turn it on and off very rapidly — at rates, in fact, as high as 150,000 flashes per minute.

Electronic control of flashing lamp permits accurate setting and knowledge of flashing rate, and this capability leads to the widespread use of stroboscopes as tachometers. If one can make a moving device appear stationary by illuminating it with a light flashing at a rate equal to the device speed, one can also adjust the flashing rate

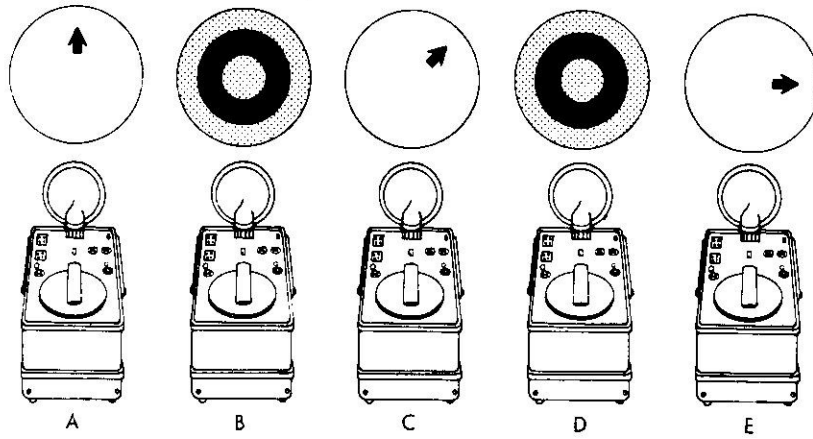

Figure 1-1. How the stroboscope produces a slow-motion image. The stroboscope above is flashing once every $1 \frac{1}{8}$ revolution of the disk. In A, a single flash catches the disk in its 0° position. In B, while the stroboscope is not flashing, the disk, rotating clockwise, makes better than a full revolution. In C, the next flash catches the disk at its 45° position. The next flash, in E, occurs after the stroboscope has made another $1 \frac{1}{8}$ revolution. The eye, retaining each image it receives for a split second, weaves A, C, and E into an image of apparent slow forward motion.

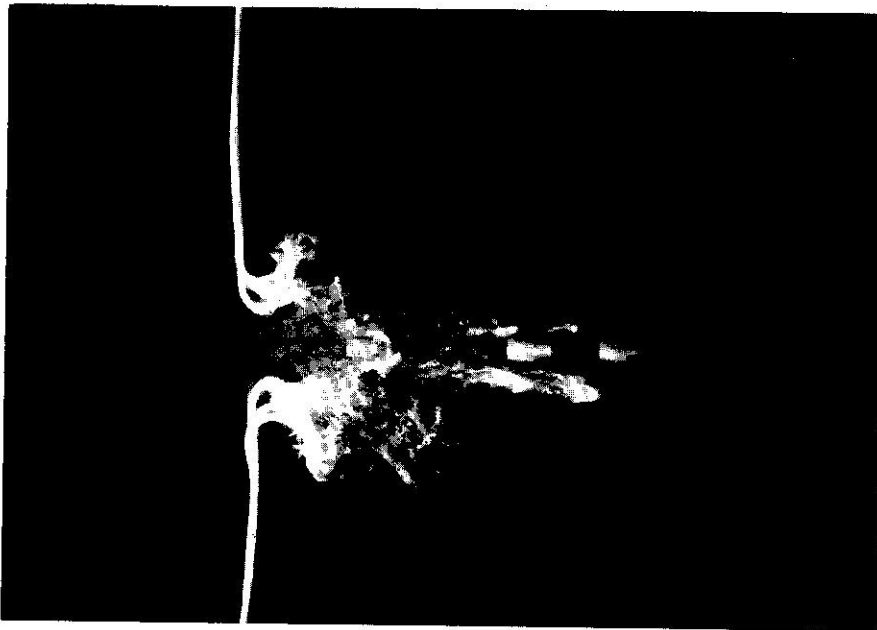

Figure 1-2. Unretouched photo of bullet breaking string shows how little even this fast-moving projectile travels during strobe flash. (Photo is multiple exposures, each image of the bullet corresponding to a single flash.)

until the device appears stationary and then determine the device speed from a knowledge of flashing rate. One marked advantage of the stroboscope over other kinds of tachometers is that it requires no mechanical connection to the device whose speed is being measured.

Whereas the eye can retain an image for only a fraction of a second, photographic film can retain it indefinitely. The short duration (about a millionth of a second) of the stroboscope's flash can be used to limit the time during which film is exposed to high-speed motion. A rifle bullet traveling at muzzle velocity moves only a few hundredths of an inch during a single flash, and can thus be clearly photographed in flight. If it is photographed under the light of successive flashes, moreover, the result is a multiple exposure in which images are separated by accurately known time intervals. This type of photography is thus often used to obtain position-vs-time data, from which velocity and acceleration can be calculated.

1.2 HISTORY OF THE STROBOSCOPE

The first stroboscopes were invented in 1832 by Stampfer of Vienna and Plateau of Ghent, each working independently of the other. Plateau called his device "phenakistoscope." Stampfer chose the name "stroboscope," which is derived from two Greek words, meaning "whirling watcher."

"Whirling watcher" may be a curious name for the modern electronic stroboscope, but it described the first stroboscopes perfectly. These were disks, with slots at regular intervals. As the disk whirled, the "watcher" looked through the slots. Thus the vision path between an object and the eye was interrupted, producing the stroboscopic effect. Some of these mechanical stroboscopes featured disks driven by chronometer motors, with speed accurately controlled by spring governors.

The primitive stroboscope was put to many ingenious uses, both as a tachometer and as a device for permitting slow-motion observation. Its tachometric talents were put to use by GenRad in 1930, in the form of a stroboscopic frequency meter. In this instrument, a disk was rotated at exactly 10 revolutions per second by a motor synchronously driven by a 1000-cycle frequency standard. The spinning disk, on which were concentric rings of 10, 20, 30, . . . etc. dots, was illuminated by a neon lamp turned on and off by an oscillator of unknown frequency. To adjust this oscillator to exactly 1000 cycles, it was necessary simply to adjust the lamp flashing rate to 100 times the disk speed — in other words, to adjust the oscillator until the 100-dot ring on the disk appeared stationary.

Another early example of stroboscopic instrumentation by GenRad was a precision chronograph, introduced in 1931. A disk with a ring of 100 uniformly spaced holes was rotated at 10 revolutions per second between a light source and a photocell. The photocell was thus energized 1000 times per second, and a string galvanometer operating from the photocell output produced a series of timing markers, 0.001 second apart, for the chronograph chart.

The principles of stroboscopy were therefore well known to GenRad engineers in the early 30's when, just down the street from GenRad's Cambridge plant, MIT Professor Harold Edgerton developed a way of producing a very brief light flash by means of a high-intensity mercury arc lasting only five microseconds. The flash rate

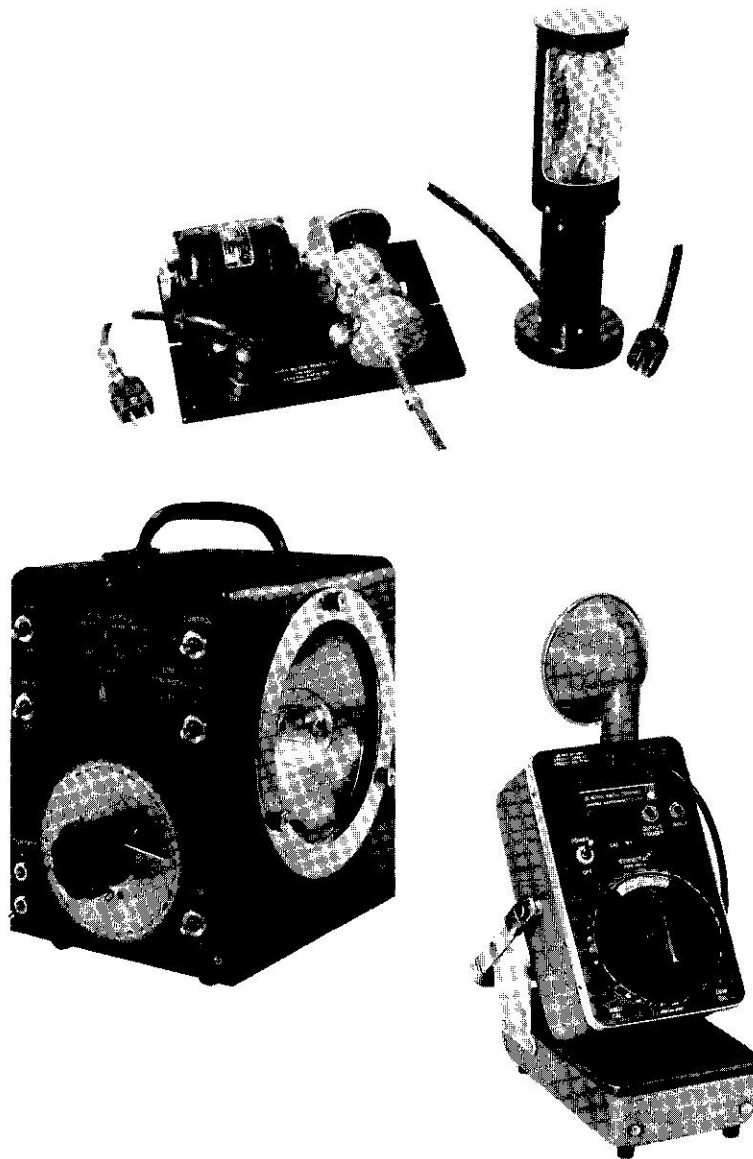

Figure 1-3. Evolution of the electronic stroboscope.

**Top: GR 548-A Edgerton Stroboscope Lamp and Type 549-A Synchronous Motor Contactor, introduced in the early '30's;
Lower left: GR 631-A Strobotac, of 1935;
Lower right: Current GR 1531-AB Strobotac.**

could be controlled accurately at speeds up to 10,000 per minute. Thus the intermittency essential to stroboscopy occurred at the light source, rather than somewhere in the light path, as with mechanical stroboscopes.

In the Edgerton stroboscope, a capacitor was discharged through a mercury-vapor tube to produce the intense, brief flash. Later stroboscope tubes used other gases — argon, krypton, and xenon. Xenon became the preferred gas because of its high efficiency of conversion from electrical energy into light and because the spectral distribution of the light produced approximates that of daylight.

The electronic stroboscope has so many advantages over its mechanical ancestors that we can date the beginning of stroboscopy as we know it from the date of the first GenRad Edgerton stroboscopes. Among the advantages of the electronic stroboscope over the mechanical are:

1. The effective illumination on the object was increased.
2. The flash duration was shortened to a few microseconds.
3. The flashing rate could be easily and precisely adjusted and accurately calibrated.
4. Several observers could view the object simultaneously. (A rotating disk or a mechanical shutter could accommodate only one observer at a time.)

The first commercial electronic stroboscope provided means for adjusting the flash rate over a wide range, but lacked any scale by which the user could tell how fast the stroboscope was flashing. The first stroboscope to feature such calibration was the GR 631-A, which was introduced in 1935. Now the stroboscope could be used not only for observation of moving objects, but also as a tachometer to indicate the speed in rpm. This first stroboscopic tachometer was trade-named the Strobotac[®], a name used ever since to describe GenRad electronic stroboscopes.

The latest versions of the Strobotac[®] electronic stroboscope are:

The GR 1531-AB Strobotac*, with an internally controlled flashing rate up to 25,000 per minute, plus provision for triggering by external means;

The GR 1538-A Strobotac, similar to the 1531-AB but with flashing rate up to 150,000 per minute, battery as well as ac operation, an optional extension lamp for use in tight places, and provision for a plug-in capacitor to increase the light intensity for single-flash use;

The GR 1539-A Stroboslave[®] stroboscopic light source, similar to the 1531-AB but requiring external control of flashing rate.

The GR 1540 Strobolume[®] electronic stroboscope, a high-intensity stroboscopic light source whose flashing rate is controlled by a Strobotac, contactor, or internally to 25,000 per minute.

These instruments and accessories are described in detail in Chapter 2.

**"Strobotac," a registered trade name, is properly used as an adjective to describe electronic stroboscopes manufactured by GenRad. In view of the frequent references to these instruments in this book, we will hereafter use the term "Strobotac" alone.*

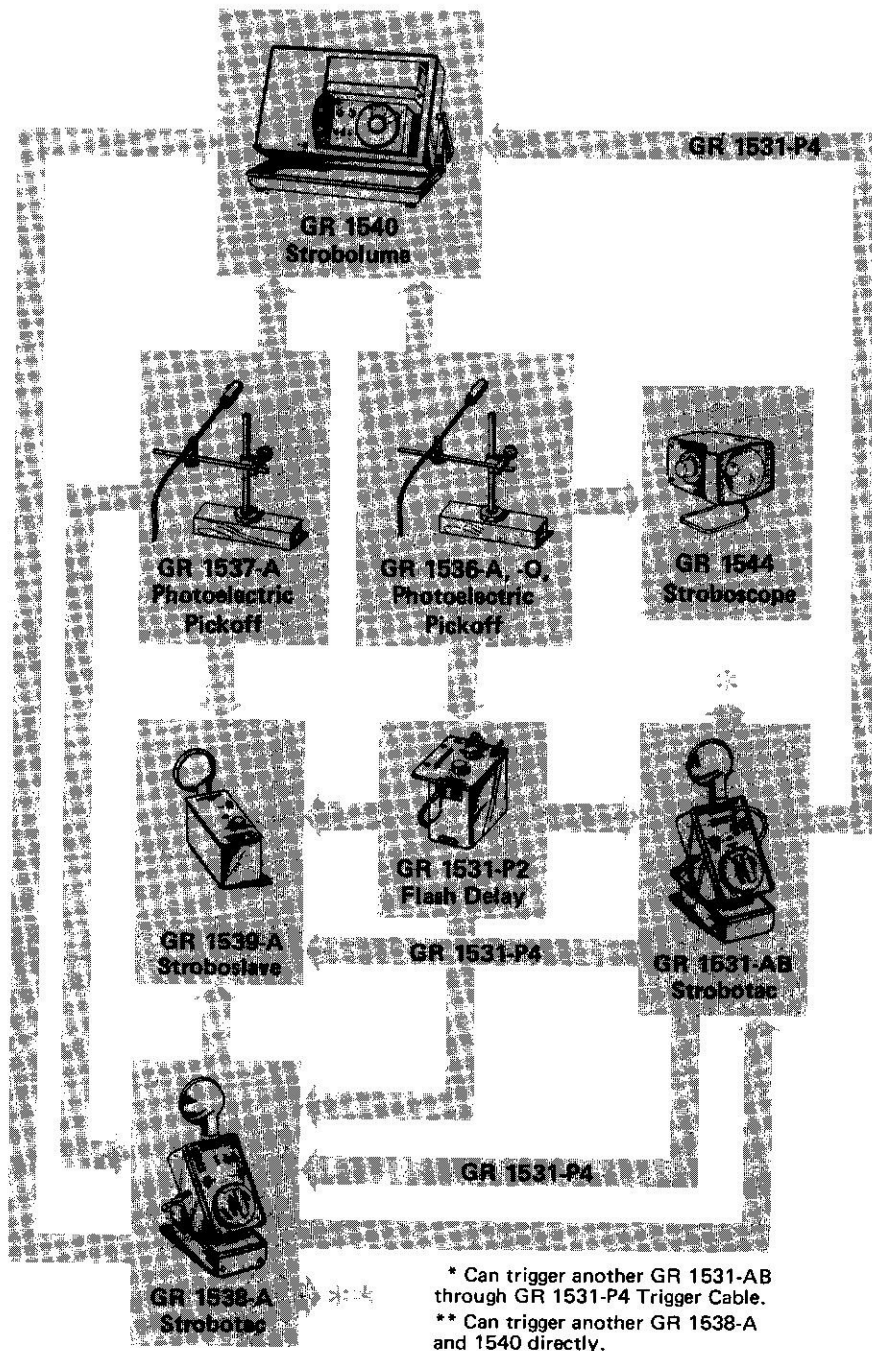

Figure 2-1. The GenRad line of stroboscopes and accessories.

GenRad Stroboscopes and their Accessories

2.1 THE GENERAL-PURPOSE STROBOSCOPE (GR 1531-AB Strobotac electronic stroboscope)

The direct descendant of the early stroboscopes described in the previous chapter is the GR 1531 Strobotac. It is lighter and much more compact than its predecessors. More important, its light is much brighter and its flashing-rate limit much higher.

The Strobotac includes a strobotron tube with its associated discharge capacitors, a triggering tube to fire the strobotron, and oscillator to determine flashing rate, and a power supply.

The Strobotac has two basic operating modes. In one, the flashing rate is controlled by the internal oscillator and is indicated on the RPM dial. In the other, flashing rate is controlled by an external contactor or electrical signal. Under internal control, the Strobotac covers a flashing-rate range of from 110 to 25,000 flashes per minute in three direct-reading ranges: 110 to 690, 670 to 4170, and 4000 to 25,000. By use of harmonic techniques (see paragraph 3.4), speeds up to 250,000 rpm can be measured. Accuracy is $\pm 1\%$ of dial reading after calibration. (The Strobotac is calibrated against power-line frequency.)

With the range switch set at one of its three EXT INPUT positions, the Strobotac can be triggered by an electrical signal of at least 6 volts peak-to-peak (2 volts rms sine-wave signal down to 5 Hz) or by a set of make-break contacts connected to the INPUT jack. Flashing rates under external control may be as high as 36,000 rpm with, of course, no lower limit. The three EXT INPUT positions of the range switch offer increasingly higher maximum flashing rates (as marked on the dial) at decreasing peak light intensities.

Flash duration is approximately 0.8, 1.2, and 3 microseconds for the high-, medium-, and low-speed ranges, respectively, measured at one-third peak intensity. Peak light intensity on the high-, medium-, and low-speed ranges is typically 0.6, 3.5 and 11 million beam candles, respectively. For a single flash, it is 18 million beam candles.

Reflector beam angle is 10 degrees at half-intensity points. A negative triggering pulse of 600 to 800 volts, available at a panel jack, can be used to synchronize other devices, including other stroboscopes.

The Strobotac requires a power supply of 105 to 125 (or 210 to 250) volts, 50 to 400 Hz. Maximum power consumption is 35 watts.

Supplied with the Strobotac are an adjustable neck strap, a plug to fit the input and output jacks, and spare fuses. The instrument is housed in a Flip-Tilt case, which doubles as both a protective carrying case and an easel-type stand. Over-all dimensions are 10 5/8 by 6 5/8 by 6 1/8 inches. The Strobotac weighs 7 1/8 pounds.



Figure 2-2. GR 1531 Strobotac electronic stroboscope. Small photos show how Flip-Tilt case locks open for use or closed for storage or travel.

2.2 THE BATTERY-OPERATED HIGH-SPEED STROBOSCOPE (GR 1538-A Strobotac electronic stroboscope)

The GR 1538-A Strobotac is functionally similar to the 1531, but includes several important "extras." First, this stroboscope operates from a rechargeable nickel-cadmium battery (an optional accessory) as well as from an ac power line. Second, an additional high-speed range extends flashing rates up to 150,000 per minute. Also, an optional plug-in capacitor greatly increases light intensity for single-flash photography.

The four flashing-rate ranges of the 1538-A Strobotac are 110 to 690, 670 to 4170, 4000 to 25,000, and 24,000 to 150,000 rpm.

Flashing rate can be internally controlled or can be triggered by a simple external contact closure, a 1-volt positive pulse, or a 0.35-volt sine-wave signal at 100 Hz, increasing to 3.5 volts at 5 Hz.

Flash duration is approximately 0.5, 0.8, 1.2, and 3 microseconds for the four speed ranges (highest to lowest, respectively), measured at one-third peak intensity.

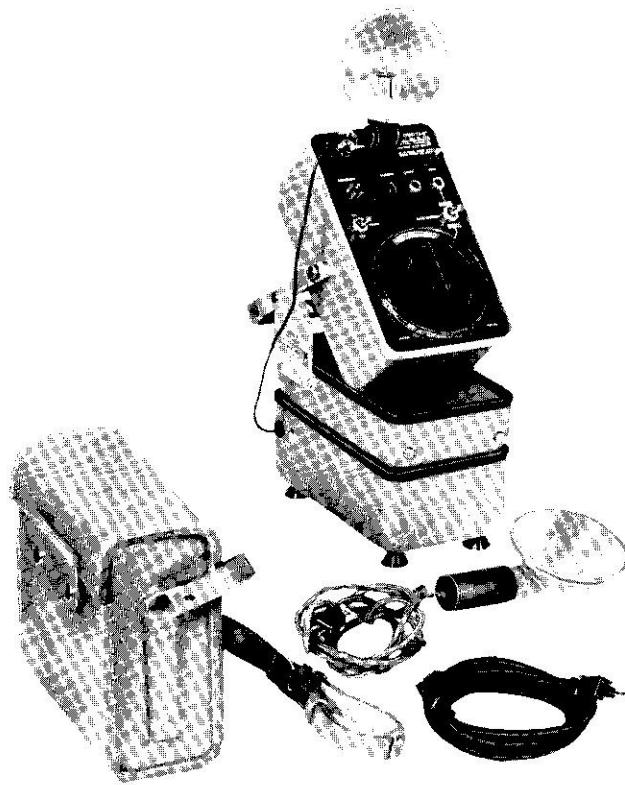

Figure 2-3. GR 1538-A Strobotac electronic stroboscope with accessories. Left foreground, in leather case, are battery and charger. Power cable is in right foreground, and extension lamp is next to Strobotac, which sits atop plug-in high-intensity-flash capacitor.

Peak light intensity is typically 0.16, 1, 5, and 15 million beam candles for the four speed ranges, from highest to lowest, respectively. For a single flash with the plug-in capacitor, the single-flash peak intensity is typically 44 million beam candles.

The battery power supply is a separate unit that need not be carried when ac power is available. The nickel-cadmium battery can be recharged from the regular ac power line overnight.

Another optional feature of this Strobotac is an extension lamp with a six-foot cord that plugs into the front panel.

2.3 THE SLAVE STROBOSCOPE (GR 1539-A Stroboslave)

In many stroboscope applications, flashing rate is controlled exclusively by external means, without any need for an internal oscillator. The GR 1539-A Stroboslave is designed for such applications. This very small stroboscope flashes either upon closure of external contacts or upon reception of a 2-volt positive pulse at its INPUT jack. It can be controlled by either a 1538-A or, with a 1531-P4 Trigger Cable, a 1531 Strobotac. It can also be triggered by a photoelectric pickoff or mechanical contactor. There is no internal means for controlling flashing rate.

Light output is the same as for the 1531 Strobotac. The Stroboslave is in fact comparable to the Strobotac in all respects except that it cannot be used as a tachometer.

The strobotron (flash lamp) is at the end of a six-foot cord, permanently attached to the instrument. Power requirement is 100 to 125 (or 195 to 250) volts, 50 to 400 Hz.

Because of its small size (2½ by 8¾ by 2¾ inches), the Stroboslave makes an ideal built-in accessory for machines requiring stroboscopic monitoring.

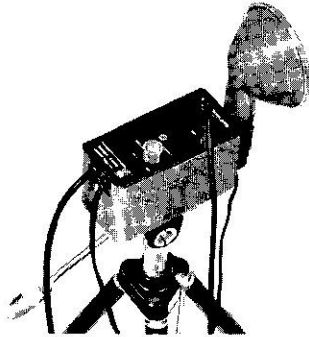

Figure 2-4. GR 1539-A Stroboslave. Like the Strobotac stroboscopes, the Stroboslave mounts on a 1/4 x 20 thread tripod (not supplied).

2.4 THE HIGH-INTENSITY STROBOSCOPE (GR 1540 Strobolume)

The 1540 might well be considered a stroboscopic "floodlight". Its high-intensity flash combines with a wide beam angle to effectively illuminate both large-sized subjects and subjects that are in areas having high ambient-light levels. Three control units are available to permit either slaved, speed-measuring, X-synced single-flash-photographic or delayed-flash motion-analysis operations. These control units are described in paragraph 2.5.

The flash from the Strobolume provides about 20 times more light output for any corresponding flash-rate setting than the Strobotac. The 1540 Strobolume is ideal for high-speed photography; for example, the unit, at its highest flash intensity, has a guide number of 70 for High-Speed Ektachrome (ASA 160). Auxiliary booster capacitors can be added for even higher single-flash intensities. The beam angle can be adjusted from a wide 7 x 13-foot pattern to a narrow 3 x 13-foot pattern (at a 10-foot distance). The flashing rate of the 1540 can be adjusted continuously from a low of 30 to a high of 25,000 flashes per minute. Flash duration is 15 μ s, 12 μ s, and 10 μ s on the high-, medium-, and low-intensity positions.

The packaging of the 1540 Strobolume is unique in that the power supply, control unit, and lamphead separate and cable connect for applications requiring a remote light source. For one-hand operation, the lamphead and control unit attach into a single integral unit. Or, the lamphead can be conveniently mounted on a tripod, with or without its control unit.



Figure 2-5. GR 1540 Strobolume in a photographic setup.

2.5 STROBOLUME CONTROL UNITS (GR 1540-P1, 1540-P3, 1540-P4)

GR 1540-P1 Strobolume Oscillator. This unit, Figure 2-6 (A), makes the 1540 essentially a high-power Strobotac. Designed for speed measurements, the 1540-P1 features a calibrated flashing-rate control for $\pm 1\%$ measurements from 110 to 25,000 rpm. Speeds up to 250,000 rpm can be measured by harmonic techniques. It can also be externally triggered (see Table 4-1), has a trigger output, and a push-button for unsynchronized single-flash photography.

GR 1540-P3 Strobolume Control Unit. Actually with this unit, Figure 2-6 (B), the control of the Strobolume comes from an external triggering source such as

another stroboscope, 1537 Photoelectric Pickoff, or a contacting mechanism. This unit makes the 1540 an ideal slave light source for the Strobotac (when used with a 1531 Strobotac, a 1531-P4 Adaptor cable is required).

GR 1540-P4 Oscillator/Delay Unit. The ideal control for motion analysis and high-speed photography, this unit, figure 2-6 (C), has a delay circuit much like the 1531-P2 (see paragraph 2.8). An amount of time delay adjustable from 100 μ s to 1 s can be inserted into the triggering circuit to delay the time at which an external input signal will flash the 1540. This permits phasing of the flash with the motion of the subject to allow both visual and photographic analysis in a point-by-point manner. An input is provided for cameras having X-sync, for both delayed and non-delayed synchronized single-flash photography. The 1540-P4 will accept a variety of input trigger signals (see Table 4-1). One unique feature not found in other GenRad stroboscopes bears mentioning. When the 1540-P1 is used with photoelectric pickoffs, it can be made to trigger from either a reflective or nonreflective mark. This is described in paragraph 2.7. In addition, the 1540-P4 has an adjustable uncalibrated oscillator for varying flash rate from 30 to 25,000 flashes per minute. A pushbutton is also provided for burst-flashing the 1540 for multiple-exposure photography.

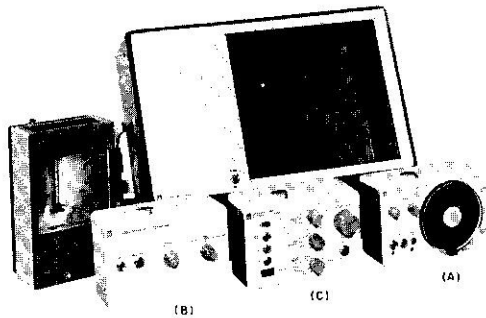

Figure 2-6. The GR 1540 Strobolume and Control Units.

2.6 INEXPENSIVE INSPECTION STROBES (GR 1542, 1543, 1544)

2.6.1 General.

This new family of GenRad stroboscopes brings the economies of the latest design concepts and manufacturing techniques to the traditional quality inherent in GenRad instruments.

These strobes feature simple pushbutton control with a single knob to control the flash rate — no range switching is ever necessary. They include unique electronically compensated light output for subjectively constant image brightness (as the flash rate decreases, the light intensity increases) and are housed in a tough plastic case that is shaped for comfortable hand-held operation and includes a threaded hole for tripod mounting.

2.6.2 GR 1542 — Simple, Economical.

The 1542 is as easy to operate as an extension lamp. Plug in the attached power cord, push the ON-OFF button, point the light at the action, and turn one knob

until the visual image of the action slows to the desired rate or stops. That's the sum total of the operation — plug, push, point, and turn!

2.6.3 GR 1543 — Bright, Triggerable.

The 1543 is similar to the 1542, except its light output is much greater and it contains two additional pushbuttons. One button allows the flash to be triggered by an external contact closure, a must when the motion is a periodic or erratic, or when perfect synchronism is desired, such as with a camera for high-speed photographs. The other button allows the internal oscillator to be synchronized to a sub-multiple of the line frequency, to permit flash rates of the same high accuracy and stability as the line frequency; very handy for studies of line-frequency-related motion, or for photographic studies of acceleration and velocity.

2.6.4 GR 1544 — Delay Triggerable.

The 1544 provides all the features of the 1543 plus two more peculiar to it alone. It can be externally triggered from positive pulses and from a photo pickoff, in addition to contact closures. And, at the push of a button, the occurrence of its flash can be delayed from the application of the trigger. The delay is continuous from 16 to 330 milliseconds and controlled by the same knob that controls the flash rate.

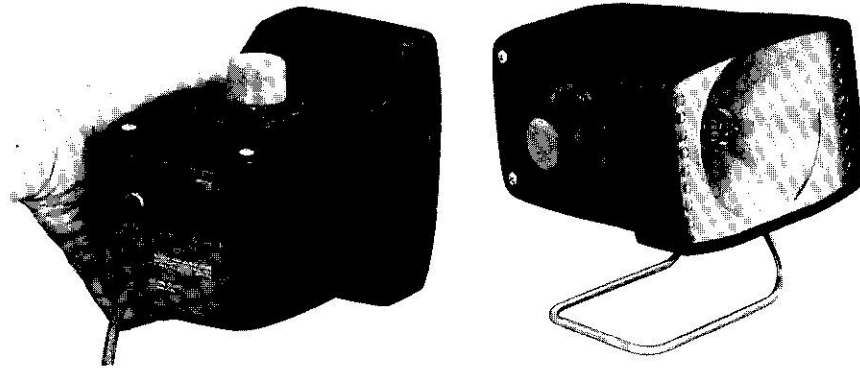

Figure 2-7. GR 1543 Stroboscope, an inexpensive yet complete and versatile stroboscope. It can be hand held (left) or mounted on stand supplied (right). The 1544 is nearly identical in appearance, while the 1542 is similar in shape but slightly smaller.

2.7 PHOTOELECTRIC SYNCHRONIZERS/CONTACTORS (GR 1536-A, 1536-O, and 1537-A)

The GR 1536-A Photoelectric Pickoff includes a light source, a concentrating lens, a photocell, an output cable, and the linkage, C-clamp, and magnet for mounting the assembly. The principle of operation is simple: A piece of reflective tape is affixed to the object to be observed and the pickoff, containing the light source, lens, and photocell, is aimed at the object. Upon each passage of the reflective tape by the pickoff, light from the tape is reflected back to the photocell, and a small electrical pulse is generated. This pulse, after amplification, fires the stroboscope.

The pickoff can also be triggered by direct light passing through openings in the object being observed or in a synchronizing disk.

The output pulse from the photocell requires amplification if it is to trigger the Strobotac. Also, the pickoff requires power, 20 to 28 volts dc, 40 mA. Both amplification and power are supplied by the 1531-P2 Flash Delay or the 1540-P4 Oscillator/Delay, which also provides delay control (refer to paragraph 2.8).

Maximum pulse rate of the photoelectric pickoff is 2500 per second, much higher than the flashing rate of the 1531 or the 1540 and equal to the maximum flashing rate of the 1538-A Strobotac. The limitation is imposed by the 200-microsecond time constant of the photocell-cable combination.

Where the 1536-A pickoff is to be operated by reflected light, the object to be observed must be equipped with reflective tape (supplied) or, if the object itself is reflective, with nonreflective tape (also supplied).

The Photoelectric Pickoff includes a mounting assembly made up of two 5/16-inch-diameter stainless-steel rods, 6 and 6 1/4 inches long, adjustable connecting clamps, a magnetic base, and a C-clamp.

The 1536-O pickoff is electronically identical to the 1536-A and can be used with the same equipment. They differ only in mechanical details. The 1536-O is designed to be permanently attached to a machine such as a printing press, processing equipment, etc. It is contained in a 0.75-in.-27 threaded housing to which is attached a removable 15-foot cable terminated with a 3-wire telephone plug.

The 1537-A Photoelectric Pickoff is similar to the 1536-A but includes no light source. It is designed to be used with an external light source to which it is periodically exposed by a mechanical disk or reciprocating shutter coupled to the machine being observed. The 1537-A Pickoff is connected directly to a 1538-A Strobotac, a 1539-A Stroboslave, or a 1540 Strobolume. It is much less sensitive and less versatile than the combination of 1536-A Pickoff and 1531-P2 Flash Delay, and should be used only where a relatively bright light is available to trigger the photocell.

When the 1536 or 1537 is used with a 1540-P4 Oscillator/Delay Unit, either "light" or "dark" triggering can be used. That is, a piece of reflecting tape on a dark background or a nonreflecting tape on a light or reflecting background.

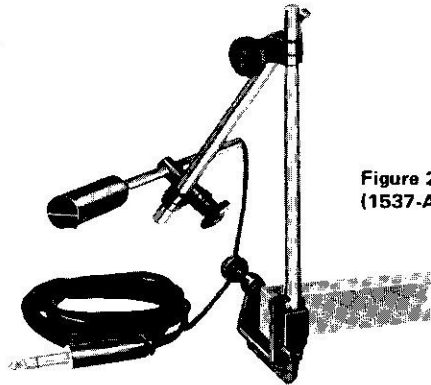

Figure 2-8. GR 1536-A Photoelectric Pickoff (1537-A is almost identical in appearance).

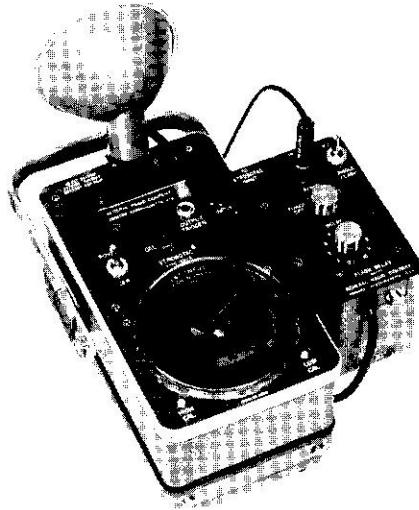

Figure 2-9. GR 1531-P2 Flash Delay, shown mounted on Strobotac.

2.8 THE FLASH-DELAY UNIT (GR 1531-P2 Flash Delay)

The GR 1531-P2 Flash Delay, connected between the photoelectric pickoff and the stroboscope, inserts an adjustable time delay of from 100 microseconds to 0.8 second between the triggering pulse from the pickoff and the flash of the stroboscope. Such controlled delay allows the operator to see stroboscopically any point in the cycle being observed. In addition to this primary purpose, the Flash Delay also powers the 1536-A Photoelectric Pickoff and amplifies its output to better than 13 volts to drive the Strobotac or Stroboslave. With as little as 0.3 volt input, the Flash Delay will still provide enough output to operate the Strobotac.

In high-speed photography, where precise timing is especially important, the Flash Delay can be used to assist in establishing the desired sequence of events. If the X flash-synchronization contacts of the camera are connected to the jack next to the power cord on the Flash Delay, the Flash Delay will not pass a triggering pulse until after the shutter opens, and then will pass only a single pulse. Another use for the camera jack on the Flash Delay: The 1531 Strobotac, which is normally fired by the opening of a set of external contacts, can be fired by contact closure if the contacts are connected to the camera jack and the output of the Flash Delay is connected to the input of the Strobotac.

For applications where the camera shutter can be opened and closed manually, a pushbutton switch (supplied with the Flash Delay) connected to the camera jack can be used to arm the circuits to fire the Strobotac directly upon receipt of a pulse from the photoelectric pickoff.

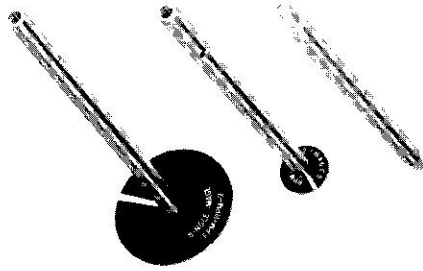

Figure 2-10. GR 1531-P3
Surface Speed Wheel.

2.9 SURFACE SPEED WHEELS (GR 1531-P3 Surface Speed Wheel)

The GR 1531-P3 Surface Speed Wheel consists of two nylon disks, each marked with a single white radial stripe, and a sectioned steel rod on which the disks can rotate freely. The circumference of one disk is 0.5 foot, of the other, 0.2 foot. If one of these disks is held against a moving belt and thus made to rotate at the belt's speed, a stroboscopic measurement of disk speed can be easily converted to belt feet per minute.

The larger wheel is designed for the measurement of relatively high linear speeds, up to 12,500 feet per minute. With the stroboscope set to the disk speed, the linear speed of the moving surface in feet per minute is the stroboscope dial reading divided by 2.

The smaller wheel is used for linear speeds from 10 to 2500 feet per minute. With this wheel, the stroboscope is set to twice the disk speed (a single radial line is made to appear a full diameter). Then the stroboscope RPM dial reading is divided by 10 to give linear speed in feet per minute.

The Stroboscope as a Tachometer

3.1 GENERAL PRINCIPLES

When a periodically moving object is illuminated by flashes of light from a stroboscope, the object appears to move at a speed equal to the difference between the flashing rate of the stroboscope and the cyclic rate of the object. When this difference is zero (i.e., when flashing rate equals cyclic rate), the object appears stationary. Thus, if the moving object appears stationary, the speed* of the object can be derived from the stroboscope flashing rate, which is indicated on a calibrated dial. On most modern stroboscopes, the flashing-rate calibration is given in terms of flashes per minute (numerically equal to rpm).

The stroboscope offers many advantages over other types of tachometers. It absorbs no power from the device whose speed is being measured and can thus be used with delicate mechanisms and low-torque motors. It is fast enough to catch the highest-speed motion. It can be aimed at machine parts inaccessible to other tachometers. And it is much more accurate than most mechanical tachometers (the Strobotac measures speeds to within one percent).

To serve as a tachometer, a stroboscope must include its own flashing-rate control circuits and calibrated dial. Thus the 1531 and the 1538 Strobotac, as well as the 1540 Strobolume, can be used as tachometers, but the 1539 Stroboslave cannot.

3.2 FUNDAMENTAL SPEED MEASUREMENT

If the speed to be measured is within the flashing rate range of the stroboscope (110 to 25,000 rpm for the 1531 and the 1540, 110 to 150,000 rpm for the 1538-A), it can be measured directly from the stroboscope dial. Otherwise, harmonic techniques (see paragraph 3.4) are used. The Strobotac has overlapping speed ranges: 110 to 690 rpm, 670 to 4170 rpm, 4000 to 25,000, and, for the 1538-A only,

*The term "speed" is loosely but commonly used to denote rate of repetitive motion. "Repetition rate" would be more correct.

24,000 to 150,000 rpm. In most cases, the approximate speed to be measured will be known well enough so that the proper range can be selected. Otherwise, it is best to start at the highest range and work down.

Although the Strobotac can be flashed at rates down to 110 per minute, flicker is pronounced at speeds much below 600 rpm, where the eye's persistence of vision is strained to maintain the stroboscopic illusion. Also, at lower speeds the eye responds to peak rather than to average intensity, and the peak intensity in turn increases by a factor of 6 as the flashing-rate range control is switched to the next lower speed range. The resultant increase in brightness makes it easier to observe the subject, especially in high ambient light, but it also intensifies the annoyance of flicker.

In adjusting the stroboscope flashing rate for a single stationary image, one must be careful to avoid being confused by harmonics or subharmonics. Spurious images are especially confusing when the object being viewed is symmetrical; a four-bladed fan, for instance, will appear stopped when the stroboscope is flashing at twice and at four times the fan speed. That particular problem is solved easily by a crayon mark placed on one of the four blades. **In all speed measurements on symmetrical devices, the introduction of some asymmetrical feature is strongly recommended to avoid confusion.**

The subharmonic problem is another matter. Even with an asymmetrical object, the correct fundamental image is repeated when the stroboscope is flashing at one-half, one-third, etc, the speed of the object. Flashes are then occurring every other revolution, and so on, and even though such submultiple images appear progressively dimmer, they can be confusing. The proper setting, then, for a fundamental speed measurement, is the highest setting at which a single stationary image can be achieved. Even this rule is subject to further qualification, inasmuch as the fundamental could be beyond the flashing-rate limit of the stroboscope.

There are several ways in which the user can distinguish fundamental from submultiple. He can decrease the flashing rate until another single image appears. If this occurs at half the first reading, the first reading was the actual speed of the device. If it occurs at some other value, then the first reading was a submultiple. Or the user can double the flashing rate and check for a double image. Finally (and most simply), he can flip the range switch to the next higher range. Because of the 6-to-1 relationship between ranges, a 6-to-1 pattern should appear.

The 6-to-1 relationship between ranges, incidentally, makes it very convenient to convert speed readings from revolutions per minute into cycles per second. One simply flips to the next lower range and mentally divides the new reading by 10.

3.3 ACCURACY OF MEASUREMENT

The basic accuracy of the Strobotac is $\pm 1\%$ after calibration. The built-in calibration circuit uses the power-line frequency as a reference, standardizing the flashing rate at two points: the power-line frequency and one-fourth that frequency. After such standardization, the Strobotac is accurate to within 1% on all scales. This means, for instance, that if the speed indicated on the dial is 2500 rpm, the actual speed is known to be between 2475 and 2525 rpm.

3.4 RANGE EXTENSION BY HARMONIC TECHNIQUES

3.4.1 General.

Stationary images of moving objects can be produced not only by flashes at the same speed as that of the objects, but also by flashes occurring at integral multiples and submultiples of the actual speed. If the flashing rate is an integral submultiple of the object's speed, a single stationary image appears. If the flashing rate is an integral multiple of the speed, a multiple stationary image appears. These relations are used to measure speeds above and below the flashing rate range of the stroboscope.

3.4.2 High-Speed Measurements

If a device is rotating at, say, 36,000 rpm, the stroboscope will produce a single stationary image at flashing rates that are integral submultiples ($1/2$, $1/3$, $1/4$. . . $1/n$) of 36,000. For measurement of speeds beyond the fundamental range of the stroboscope, these submultiples are located and used to establish the harmonic series and thus the actual speed of the object.

Two important considerations must be here noted: First, the term "single stationary image" means an image that corresponds to the appearance of the object when it is stationary. If the object has multiple features, so will the "single" stationary image. Second, if the object is symmetrical in appearance, it will be impos-

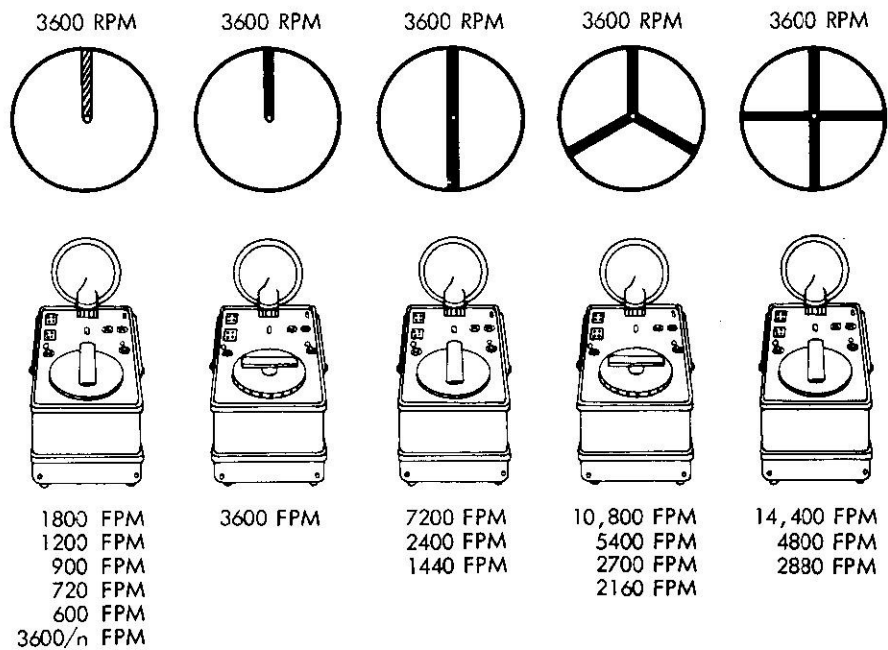

Figure 3-1. Diagrams showing the images obtained at harmonic and subharmonic flashing rates.

sible to distinguish integral submultiples from other submultiples. Therefore, the introduction of some asymmetrical characteristic is again required.

The procedure for making speed measurements beyond the range of the stroboscope is as follows: The user sets the stroboscope to its maximum flashing rate and slowly decreases the rate until a single stationary image is obtained. This rpm setting is noted as one submultiple. Then the rate is further decreased until the next single image appears, and this submultiple is also noted. Further submultiples may be found in the same manner.

The formula for calculating the fundamental speed from two successive submultiple speeds (X and Y) is as follows:

First calculate the harmonic number, n, by:

$$n = \frac{Y}{X-Y}$$

and round off the value of n to the nearest whole number.

Then calculate the fundamental speed, S_f , by

$$S_f = nX$$

For example, if X is 22,500 and Y is 16,800, then:

$$n = \frac{16,800}{22,500 - 16,800} = 2.95 \cong 3$$

and the fundamental speed is:

$$S_f = 3 \times 22,500 = 67,500 \text{ rpm}$$

Nomographs given in Appendix A reduce such calculations to a few seconds' work with a straightedge.

The formula for calculating the fundamental speed from three or more successive submultiples is as follows:

$$\text{fundamental} = (n - 1) \frac{XY}{X - Y}$$

where X is the highest of the submultiples
 Y is the lowest of the submultiples
 and n is the number of submultiples

For example, if seven successive submultiples are noted, the highest at 22,450 and the lowest at 12,050, the fundamental is

$$6 \left(\frac{22,450 \times 12,050}{22,450 - 12,050} \right) = 156,072 \text{ rpm.}$$

This calculation can be refined as follows: Divide the calculated fundamental by the highest submultiple, rounding off to the nearest integer. Then multiply the highest submultiple by this rounded-off number. In our example:

$$156,072 \div 22,450 = 6.9$$

$$7 \times 22,450 = 157,150 \text{ rpm.}$$

3.4.3 Low-Speed Measurements

When the flashing rate drops below about 10 per second (600 rpm), the persistence of vision is no longer able to span the gaps between flashes, and the result is flicker. One method of extending the range of speed measurement downward is to use multiple images.

FAN STOPPED	FAN ROTATING 1800 RPM			
 <p data-bbox="418 779 581 800">UNMARKED FAN</p>	 <p data-bbox="656 726 1252 800">ABOVE IMAGE PRODUCED AT FOLLOWING FLASHING RATES: 7200, 3600, 2400, 1800, 1440, 1200, 1029, 900, 800, 720, 600, 450, & OTHERS.</p>			
 <p data-bbox="440 1230 574 1251">MARKED FAN</p>	 <p data-bbox="630 1136 841 1178">IMAGE PRODUCED AT FLASHING RATES OF</p> <p data-bbox="711 1188 760 1251">3600 1200 720</p> <p data-bbox="667 1251 802 1304">$\frac{2}{2n + 1} \times 1800$</p>	 <p data-bbox="857 1136 1068 1178">IMAGE PRODUCED AT FLASHING RATES OF</p> <p data-bbox="938 1188 987 1293">7200 2400 1440 1029 800</p> <p data-bbox="878 1283 1013 1335">$\frac{4}{2n + 1} \times 1800$</p>	 <p data-bbox="1084 1136 1312 1178">TRUE IMAGE PRODUCED AT FLASHING RATES OF</p> <p data-bbox="1170 1188 1235 1293">1800 900 600 450 1800/n</p>	

Figure 3-2. The importance of marking a symmetrical object is shown in the above drawings, where the unmarked fan appears the same at many flashing rates, while the marked fan reveals harmonious flashing rates as such. With marked fan, true speed is equal to highest flashing rate that produces a true image.

If the flashing rate of the stroboscope is twice the fundamental speed of the device, two images, 180 degrees apart, will appear. At three times the fundamental speed, three images, 120 degrees apart, will appear. Thus, for instance, a stroboscope flashing 200 times per minute will produce a double image of a device rotating at 100 rpm. The multiple-image technique is best suited for use with objects that are simple and asymmetrical.

3.5 THE MEASUREMENT OF MECHANICAL SLIP

Stroboscopes are widely used to measure the difference in speed between a belt-driven device and the driving shaft, i.e., the slip introduced by the belt. With the aid of a stroboscope, for example, an inspector in a textile plant can synchronize the stroboscope flash with one spindle and then quickly check a line of spindles operating on the same shaft by directing the stroboscope at each. If there is no slip, all the spindles will appear stationary. Slip can be easily detected and measured as the rate of apparent motion of any observed spindle. Suppose, for example, that the stroboscope has been set to the desired spindle speed of 9000 rpm. A spindle stroboscopically observed to be moving backward at the rate of ten revolutions every four seconds (or 150 rpm) is thus operating at only 8850 rpm (9000 - 150), and appropriate measures can be taken to bring it up to proper speed. In terms of efficiency, the stroboscope is indispensable in such applications, and it is easy to understand why stroboscopes are basic equipment in most textile plants.

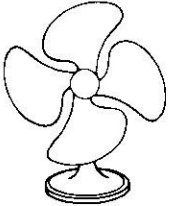
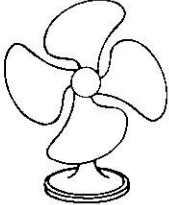
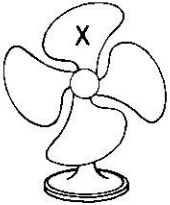
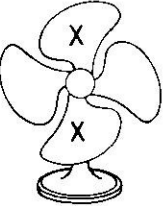
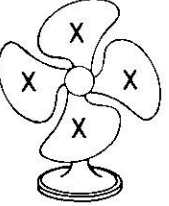
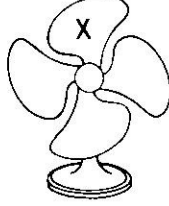
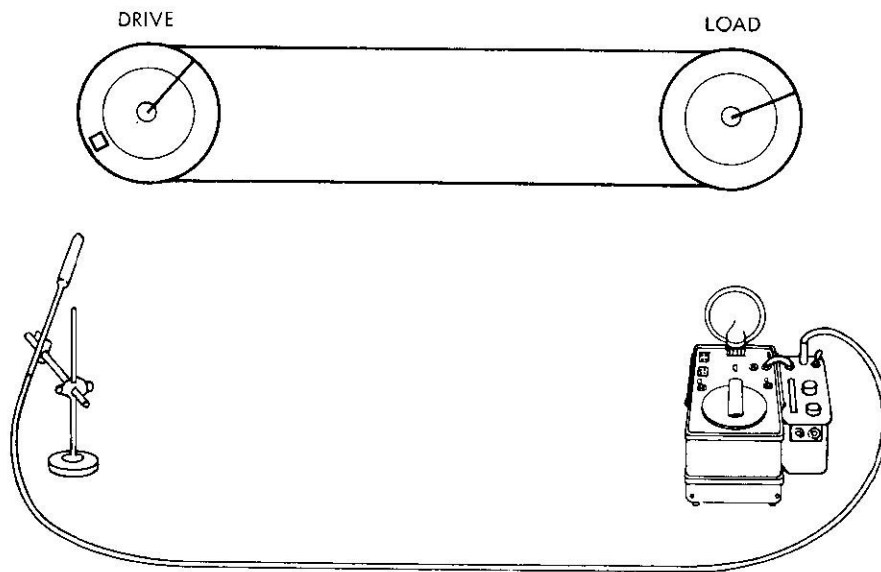

Figure 3-3. A method of measuring belt slippage is to observe load under stroboscopic flashes photoelectrically synchronized with drive shaft. A simpler way is to adjust stroboscope flashing rate for stopped image of drive shaft, then carry strobe to loads to check slippage.

3.6 LINEAR SPEED MEASUREMENT

At times it may be desirable to measure the linear speed of a device rather than the number of revolutions per minute. The surface speeds of drums, wheels, and rollers and the linear speeds of belts and pulleys can be measured stroboscopically with the aid of a simple accessory known as a surface speed wheel.

The surface speed wheel is a disk that can be held against a moving surface so that a point on the wheel's circumference will move at the surface speed. The disk is marked so that its rotational speed can be measured stroboscopically in the usual manner. The diameter of the disk is chosen so that this rotational speed, indicated on the stroboscope dial, is simply related to the surface speed being measured.

The GR 1531-P3 Surface Speed Wheels, described in detail in paragraph 2.9, are sized and marked for simple conversion of linear speed into revolutions per minute. When using one of these wheels, one should hold it firmly enough against the moving surface to prevent slipping, but not so firmly that it introduces drag. Also, since the accuracy of conversion from linear to rotational speed depends chiefly on the size of the wheel, it is a good idea to measure the diameter occasionally to check for wear.

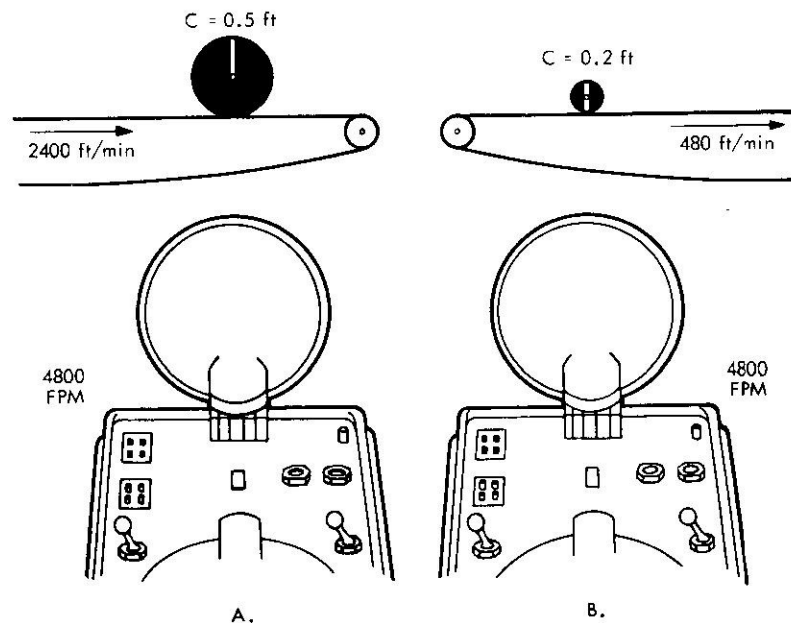

Figure 3-4. A. Larger of the two surface speed wheels gives single stationary image when flashing rate is twice the surface speed in feet per minute. Thus, in example above, belt speed is 2400 feet per minute. B. Smaller of the two surface speed wheels gives a double stationary image when flashing rate is 10 times the surface speed in feet per minute. Thus, in example, above, belt speed is 480 feet per minute.

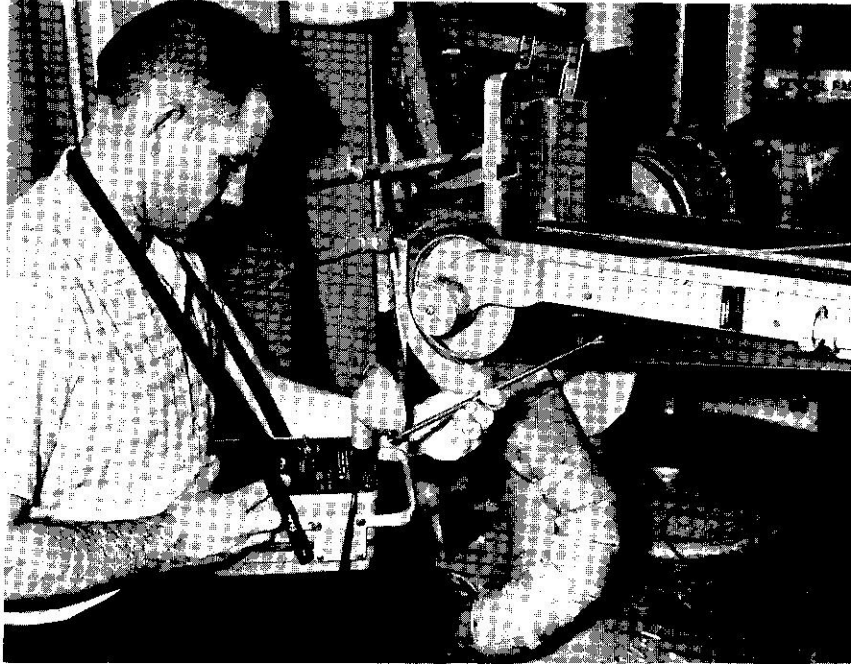

Figure 3-5. Inspector measuring belt speed with Strobotac and surface speed wheel.

3.7 CALIBRATION OF FLASHING RATE

3.7.1 General

The accuracy of stroboscopic speed measurements depends on the accuracy of the rpm dial on the stroboscope. Although all stroboscopes are factory-calibrated in accordance with published specifications, changes in power-line voltage or temperature and the aging of electronic components can introduce errors. Therefore, it is wise to check the instrument's calibration every so often. This is such a simple matter that it should be performed before any speed measurement is made.

3.7.2 Built-In Calibration System of the Strobotac

On the front panel of the Strobotac are two screwdriver adjustments, marked HIGH CAL and LOW CAL, and a neon lamp. When the Strobotac is operating at one of the CAL flashing rates, the neon lamp either glows alternately brighter and dimmer or holds a steady intensity. A steady-state intensity indicates that the flashing rate is correct in terms of the power-line frequency. If the lamp waxes and wanes in intensity, the flashing rate is off calibration, with the degree of error indicated by the rate of waxing and waning. (The higher the rate, the greater the error.)

The screwdriver adjustment marked HIGH CAL is used to calibrate the Strobotac at a flashing rate equal to the power-line frequency. After allowing the Strobotac to warm up for about 15 minutes, the user sets the rpm controls to the power-line frequency (3600 rpm for a 60-Hz power line, 3000 rpm for 50-Hz service) and adjusts the HIGH CAL control until the neon lamp holds a steady intensity (it makes no difference whether it is bright or dim, just as long as it is steady). This adjustment is not critical, and one need not spend too much time trying for a precise steady-state setting. Then the procedure is repeated with the LOW CAL adjustment and a flashing rate one-quarter of the power-line frequency (900 rpm for 60-Hz service, 750 rpm for 50-Hz service). Calibration at these two points is usually all that is required to bring the instrument to within one percent on all ranges.

If some slow variation in intensity of the neon lamp persists, it is possible to calculate the deviation from exact calibration by timing a cycle of the lamp (from on to off to on again). At the HIGH CAL point, the error in rpm equals 60 divided by the length of the lamp cycle in seconds. At the LOW CAL flashing rate, the error in rpm is 15 divided by the length of a lamp cycle in seconds.

The neon lamp will hold a steady intensity at other multiples and submultiples of the power-line frequency. It is possible, in fact, to calibrate the Strobotac at many frequencies from 1200 to 7200 rpm by adjusting for the correct glow cycle corresponding to the difference between the calibration frequency and the nearest multiple or submultiple of the power-line frequency. The general equation for such calibration is:

$$T = \frac{M}{FD}$$

where

D = the deviation from zero-beat, in rpm

M = the nearest multiple or submultiple of the power-line frequency, in rpm

F = the power-line frequency in hertz

T = the lamp cycle in seconds

For example, suppose that with a 60-Hz power line, it is desired to calibrate the Strobotac at 1875 rpm. The nearest submultiple of the power-line frequency (3600 rpm) is 1800 rpm. Therefore:

$$T = \frac{1800}{60 \times 75} = 0.4$$

The lamp should make one full cycle, then, in 0.4 second, or 10 cycles in four seconds, when the Strobotac is calibrated.

It is obvious that calibration by such means can be no more accurate than the accuracy of the power-line frequency. However, nearly all power companies hold their line frequencies within very narrow limits.

3.7.3 Calibration by Synchronous Motor and Standard Speed Disk

The glow lamp calibration technique described in paragraph 3.7.2 is intended primarily for use at exact multiples and submultiples of the power-line frequency; at intermediate points the procedure becomes more difficult. Another calibration method more useful over a wide range involves the use of a synchronous motor

driving a disk, preferably white with a single black dot near the edge. The user then calibrates the Strobotac at multiples and submultiples of the synchronous-motor speed. The following table indicates the number of dots one should see with a one-spot disk driven by a synchronous motor and illuminated by a stroboscope flashing at the rates indicated. Calibration over such a wide range requires the setting of internal potentiometers in addition to the front-panel controls.

On the top range of the GR 1538-A Strobotac, the dots are too numerous for easy counting; use of a frequency counter is recommended for calibration at such high flashing rates.

Table 3-1
FLASHING RATE (RPM)

60-Hz 1800-rpm motor	50-Hz 1500-rpm motor	Number of Dots
150	125	1
300	250	1
360	300	1
450	375	1
600	500	1
720	600	2
900	750	1
1,080	900	3
1,200	1,000	2
1,350	1,125	3
1,440	1,200	4
1,500	1,250	5
1,800	1,500	1
2,400	2,000	4
3,600	3,000	2
4,500	3,750	5
5,400	4,500	3
7,200	6,000	4
9,000	7,500	5
10,800	9,000	6
12,600	10,500	7
14,400	12,000	8
16,200	13,500	9
18,000	15,000	10
19,800	16,500	11
21,600	18,000	12
23,400	19,500	13

A HANDY HINT

The following technique is very useful when trying to determine the speed of a rotating shaft when the only possible view of the shaft is a lateral one. Usually it is not sufficient to put a single mark on the shaft and stop the motion with a stroboscope; the motion may be stopped at a flashing rate that is a multiple of the actual speed of rotation. Normally, if one were observing the end of the shaft a multiple image would be seen immediately, but it is difficult to distinguish a multiple image from a single image when one is looking at a shaft along its side.

To overcome this problem simply draw a band around the neck of the shaft but leave a small open gap. Then, draw a line in the gap at right angles to the band.

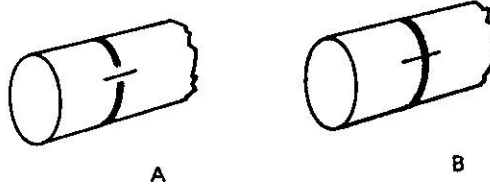

Sketch "A" will be seen only at the fundamental speed and at any subharmonics. At flashing rates higher than the fundamental a multiple image will show as a cross pattern formed by the two lines (sketch "B").

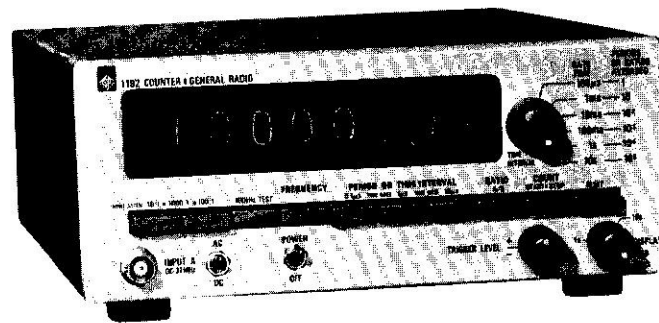

Figure 3-6. Counters can be used for precision speed measurements. The 1192 is typical of the low-cost universal counters available today. These counters can be used with appropriate transducers, such as photoelectric pickoffs, for speed measurements. They also can be connected to the output of a stroboscope to act as either a calibrator or monitor, where precise measurements are required. Counters read directly in terms of frequency, i.e., events per second. Hence, the reading must be multiplied by 60 to get rpm.

3.8 PRECISION READOUTS

The accuracy and precision with which one can measure speed by the stroboscope are limited by the physical characteristics of the stroboscope dial. After calibration, a Strobotac is accurate to within $\pm 1\%$, but even this may not be good enough for some applications. A digital counter, connected to the Strobotac output and set for a 10-second counting time, would probably improve accuracy somewhat, say to $\pm 0.2\%$. A "universal" counter, measuring period rather than frequency, would greatly increase accuracy (to $\pm 0.1\%$ or better) at lower speeds, but would involve use of a table of reciprocals to convert period to frequency.

If stroboscopic observation is not required, the combination of photoelectric pickoff and frequency counter is highly recommended for accurate, precise speed measurements.

Slow-Motion and Stopped-Motion Observation with the Stroboscope

4.1 THE STROBOSCOPIC ILLUSION

When the flashing rate of the stroboscope is an integral multiple or submultiple of the speed of the observed object, a stationary image results. When the flashing rate is near, but not at, such synchronism, a slow-motion replica of the actual motion appears. If the flashing rate is slightly below the speed of the observed object, then each successive flash occurs at a slightly later part of the cycle, and the apparent slow motion is in the same direction as the actual motion. If the flashing rate is slightly above the object speed, each successive flash occurs at a slightly earlier part of the cycle, and the apparent motion is in the reverse direction.

The optical illusion of slow or stopped motion is the basis of many important applications of the stroboscope. Of great significance is the fact that the apparent slow motion is an exact replica of the actual high-speed motion. Therefore, an irregularity in a machine's behavior that occurs only at high speeds will nevertheless be exposed in slow motion. This all-important function of slow-motion or stopped-motion visual observation is uniquely served by the stroboscope.

4.2 STOPPED-MOTION OBSERVATION

In normal operation, the flashing rate of the stroboscope is controlled by an internal electronic oscillator, and the flashes therefore occur at regular intervals. For this reason, only periodic (constant-rpm) motion can be observed stroboscopically without the use of an auxiliary synchronizing device. Mechanical and photoelectric synchronizers for observation of non-periodic motion are described in section 4.3.

Since the slow-motion effect can be produced by flashing rates near multiples and submultiples of the speed of the observed object, the range of operation can be extended by harmonic techniques, as in tachometric applications (see section 3.4).

For a given flashing-rate range on the Strobotac, the higher the speed being observed, the brighter the image and the better the slow-motion effect. At very low flashing rates, slow-motion observation is difficult because of flicker.

4.3 USE OF CONTACTORS

4.3.1 General

When the motion to be observed is not periodic, an external contactor is required to synchronize the flashes with the motion to be observed. All GenRad stroboscopes are equipped with a front-panel INPUT jack by means of which either a make-break mechanical contactor or an electrical signal can be used to trigger the flashing circuits.

4.3.2 Triggering By Make-Break Contacts

With the RPM control fully clockwise, the stroboscope will fire almost immediately (within a few microseconds) upon the opening (for the 1531) or closing (1538, 1539, 1540) of a set of contacts connected to the INPUT jack. The 1531 Strobotac can easily be set to fire upon contact closure, as follows: As the RPM dial is rotated counterclockwise, a point is reached where the stroboscope fires once, independently of external triggering. If the RPM dial is rotated further counterclockwise, the Strobotac will fire 20 milliseconds to 0.3 second after contact closure, depending on RPM dial setting. Such a relatively large delay may well be intolerable in motion studies, for which the 1531 is probably best left to fire on contact opening.

4.3.3 The Photoelectric Pickoff

The photoelectric pickoff boasts many advantages over mechanical contactors. Perhaps the greatest is the fact that, since no physical contact to the observed object is required, the photoelectric pickoff can be used with low-power devices that could not tolerate mechanical loading and with machinery inaccessible to a mechanical contactor. Another advantage is the much greater speed range of the photoelectric pickoff, which has been used successfully in the observation of devices rotating over 120,000 rpm.

The 1536-A, 1536-O, and 1537-A Photoelectric Pickoffs are described in detail in paragraph 2.7. The former includes both light source and photocell. When operated on reflected light, it must be placed within 1/2 inch or so of the object to be observed. The exact maximum allowable distance depends on several factors, including ambient light, speed of the object, and size of the tape used as a light reflector. The 1537-A Photoelectric Pickoff does not include a light source, and it must be triggered by bright light either reflected or passing directly through openings in the object being observed.

Two or more pieces of reflective tape or two or more apertures to pass light can be used on rotating objects to give a multiple stroboscopic image. Also, nonreflective tape can be used with objects that are themselves highly reflective.

Where a photoelectric pickoff is used to synchronize the stroboscope flash with the motion to be observed, the result is a stopped-motion image of the moving object **at some particular point in its cycle**. The point of observation depends on the position of the pickoff with respect to the part of the object that reflects or passes light to the photocell. Most applications require the ability to observe the object at all points throughout the cycle — in other words, to control the phase of the flashes with respect to the motion, without having to change the position of the detector.



Figure 4-1. The combination of photoelectric pickoff, flash delay, and Strobotac or Stroboslave is all that is needed for most tachometric and motion-analysis applications.

The 1531-P2 Flash Delay, shown in Figure 4-1, introduces an adjustable time difference between the sensing of motion by the 1536-A or 1536-O Photoelectric Pickoff and the firing of the stroboscope. Thus, by manipulating the control on the Flash Delay, the operator can shift the point of stopped motion continuously over the entire cycle. The amount of delay can be adjusted from 100 microseconds to 0.8 second. The slower the flashing rate, the more delay is needed to cover an entire cycle. The 1540 with a P4 Control Unit also functions in a similar manner (see paragraph 2.5).

The 1531-P2 Flash Delay performs two other important functions: It supplies power to the 1536-A or 1536-O Photoelectric Pickoff and it amplifies the triggering pulse from the photocell to the level required by the Strobotac.

The 1537-A Photoelectric Pickoff is designed for use with the 1538-A Strobotac or 1539-A Stroboslave; it cannot be used with the Flash Delay or with the 1531 Strobotac.

4.3.4 Triggering by Electrical Signal

The 1531 Strobotac can be triggered by an electrical signal of at least 6 volts peak-to-peak amplitude. It will operate with a 2-volt (rms) sine-wave signal at frequencies down to 5 Hz; below this rate the required amplitude increases. With pulse (i.e., step-wavefront) signals, the required amplitude does not vary with frequency.

The 1538-A Strobotac can be triggered by a 1-volt positive pulse or a sine-wave signal of at least 0.35 volt (rms) at frequencies down to 200 Hz, increasing to 3.5 volts at 5 Hz.

For both stroboscopes, the time delay between application of the triggering signal and the flash is about 5 microseconds.

The Strobotac requires a positive signal for triggering. Under certain conditions, however, it can be made to fire on the trailing edge of a short-duration, rectangular, negative pulse. The firing point depends on the setting of the RPM control. When this control is clockwise of the flash point (see paragraph 4.3.2), the Strobotac fires upon reception of the positive-going signal. When the RPM control is counterclockwise of the flash point, the trailing edge of a negative pulse can be used as a trigger.

Table 4-1

TRIGGERING REQUIREMENTS FOR GenRad STROBOSCOPES

Strobe Type No.	Make-Break Contacts	Photoelectric Pickoff	Electrical Signal
1531	Fires on contact opening	1536 + 1531-P2	Pos pulse: 6 V Sine wave: 2 V rms @ 5 Hz or higher
1538	Fires on contact closing	1536 + 1531-P2 or 1537	Pos pulse: 1 V Sine wave: 0.35 V rms @ 100 Hz or higher; 3.5 V rms @ 5 Hz
1539	Fires on contact closing	1536 + 1531-P2 or 1537	Pos pulse: 2 V
1540	Fire on contact closing	1537	Pos pulse: 1 V
with 1540-P1	Fire on contact closing	1537	Pos pulse: 1 V
with 1540-P3	Fire on contact closing	1537	Pos pulse: 1 V
with 1540-P4	Selectable; will fire on either closing or opening	1536 or 1537	Pos pulse: 1 V Sine wave: 0.35 V rms from 100 to 400 Hz, increasing to 3.5 V rms @ 5 Hz
1543	Fire on contact closing (isolated from ground)	None	Not Applicable
1544	Fire on contact closing (isolated from ground)	1536	Pos pulse: 1 V

The 1531 Strobotac and the 1539-A Stroboslave are susceptible to holdover in their triggering circuits caused by noise pulses generated by external switching transients or by the insertion of the input connector. With the 1531, the solution is simply to make the input connection **before** switching the RPM control to one of its EXT INPUT positions. When holdover does occur in the 1531 or 1539 stroboscope, the instrument's power switch should be switched off for a few seconds to eliminate the condition. This holdover, it should be noted, occurs in a thyatron or silicon-controlled rectifier, not in the flash tube, and is evidenced simply by failure of the stroboscope to flash.

The 1538-A or the 1540 is not subject to this type of holdover.

4.4 SLOW-MOTION OBSERVATION

The combination of contactor and stroboscope yields a stationary image of a moving object. The addition of a phase control or flash delay lets the user adjust the position of this stationary image. These devices will not, however, produce the slow-motion illusion sometimes desired.

Slow-motion observation by means of a stroboscope requires offsetting the flashing rate slightly from the speed of the object being observed. If the observed motion is periodic (constant-rpm), the stroboscope's own flashing-rate control can be used to achieve and hold the desired offset frequency. Slow-motion observation of non-periodic motion requires the use of not only an external contactor, which alone produces a 1-to-1 (or n-to-1) relation between flashing rate and object frequency, but also of an auxiliary device to offset the flashing rate for slow-motion observation.



High-Speed Photography

5.1 INTRODUCTION

High-speed photography has been defined as that requiring film exposure times shorter than the fastest mechanical shutters can provide. For still pictures, high-speed photography begins at about 1/1000 of a second; for motion pictures, at about 250 frames a second.

In high-speed photography, exposure time is usually controlled at the **light source**, rather than at the camera shutter. Instead of interrupting the light on its way to the film, the high-speed photographer can leave the shutter open and turn the light on and off very quickly. Any way of providing brief illumination is naturally of interest to the high-speed photographer. A century ago a spark from a Leyden jar was used successfully to provide high-speed photographs; today the stroboscope, with a flash duration as brief as a microsecond (a millionth of a second) and with convenient controls for triggering, has won widespread popularity among high-speed photographers.

This chapter will cover the fundamentals of high-speed photography. Those interested in a detailed discussion of the subject are referred to GenRad's *Handbook of High-Speed Photography*.

5.2 STOPPING MOTION FOR THE CAMERA

Once you have a clear idea of just how brief the stroboscope's flash is, it is easy to understand how even the fastest motion is frozen for the camera. A satellite orbiting at a speed of about 25,000 miles per hour moves, during a single flash of the stroboscope, only about one-half inch! "Slow"-moving objects such as rifle bullets are essentially stationary during a stroboscope flash (at typical muzzle velocities, distance traveled is a few hundredths of an inch). Clearly, limiting exposure time is no problem for the stroboscope-equipped photographer.

Just as important as the short flash duration is the high intensity of light output. The peak intensity of a strobe flash varies with flashing rate, from about 200,000 beam candles at the highest rates to several million beam candles at low speeds. The total light output is high enough to permit use of fairly inexpensive cameras and readily available film. For even greater single-flash light intensity, the 1538-P4 High-Intensity-Flash Capacitor, an optional accessory that plugs into the 1538-A Strobotac, increases the light intensity to 44 million beam candles.

5.3 SYNCHRONIZING FLASH WITH MOTION

Exposing film at precisely the right moment to capture high-speed motion requires automatic synchronism of the motion and the stroboscope. Either a mechanical contactor or an electrical signal can be used to trigger the stroboscope (refer to paragraph 4.3). The synchronization chain may be visualized as having three main elements: (1) the motion to be photographed, (2) contact action or signal generation, and (3) stroboscope flash. If high ambient light is unavoidable, it may be necessary to add the action of a camera shutter to the synchronization chain.

Some ingenuity is usually called for in devising the synchronization link between the motion to be photographed and the signal generation or contact action. An electrical signal is preferred to a mechanical contact action as inherently better able to keep up with such fast actions as, for instance, the flight of a bullet. The moving

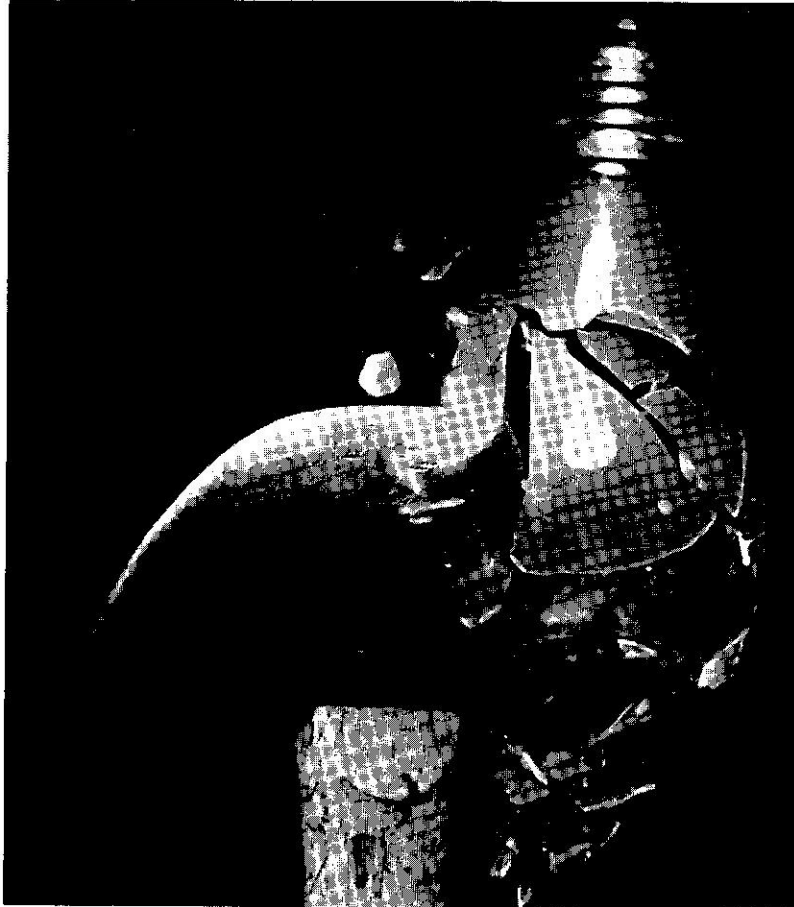

Figure 5-1. The extremely short duration of the stroboscope's flash has produced some incredible photographs, like this one of a hammer in the process of smashing a light bulb.

object can generate the electrical signal by interrupting a photoelectric beam or by opening or closing an electrical circuit. A bullet, for example, can be fired at a wire connected to the Strobotac INPUT jack, so that the resulting open circuit will produce a signal to trigger the flash. The short time interval between the breaking of the wire and the flash can be calculated and the camera aimed to lead the bullet by an appropriate amount. Other triggering techniques that have been used successfully involve photocells, microphones to detect sounds, and magnetic pickups to detect motion of ferrous objects. These methods are described in detail in the *Handbook of High-Speed Photography*.

Some delay between motion and flash is unavoidable. The object is to keep it short relative to the motion being photographed or to be able to calculate it exactly and then correct for it in the setting of the camera. If, for instance, the sound of the object is used to drive a microphone, the delay is a function of the distance between sound source and microphone. The length of this path should be chosen for the desired delay. Or the delay can be calculated from the known distance and the known speed of sound.

5.4 SHUTTER SYNCHRONIZATION

The camera shutter is left open and is thus not involved in the synchronization problem if the pictures are taken in a darkened room. If the ambient light is relatively bright, however, the camera shutter must be added to the synchronization chain.

A specific provision for synchronization of shutter and flash is a jack on the Flash Delay unit, next to the power cord. When the "X" contacts of the camera are connected to this jack, the tripping of the camera shutter will also arm the Flash Delay so that the next — and only the next — input pulse is passed to fire the Strobotac. One is thus assured that a single flash will occur sometime after the

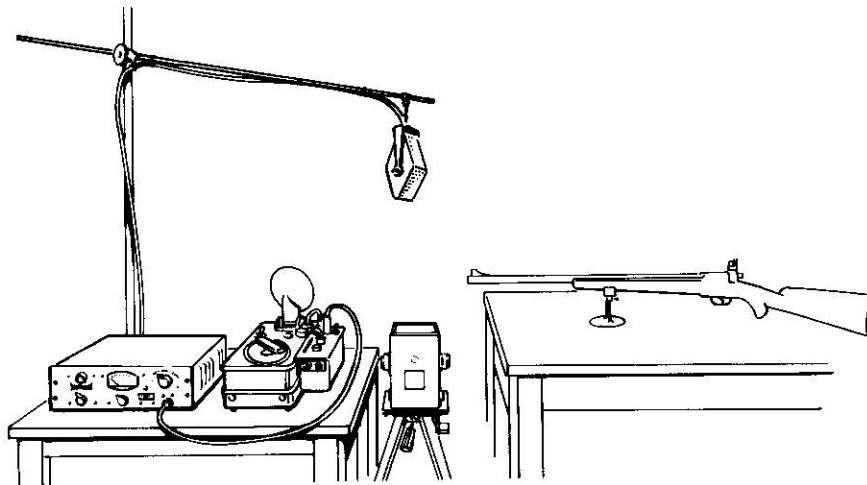

Figure 5-2. A setup for photographing a bullet in flight. Sound from shot is picked up by microphone, amplified, and fed to flash delay and Strobotac. Camera shutter is locked open, room darkened. Flash delay or microphone position is adjusted for proper synchronization.

shutter opens. To be sure that the flash occurs during the shutter-open period, one should choose a shutter speed equal to the period between the events being photographed plus any Flash Delay setting. If, for instance, the object being photographed is moving at a rate of 50 cycles per second, any shutter speed slower than 1/25 second (allowing for a delay setting) will be sure to catch at least one cycle while the shutter is open.

In practice, the shutter synchronization procedure is quite simple. With the equipment connected as shown in Figure 5-3, the Flash Delay mode switch is set to MULT and the DELAY control is adjusted until the stopped-motion stroboscopic image is exactly as the photographer would have it on film. Then the mode switch is flipped to SINGLE FLASH. When the camera shutter is tripped, a single flash will occur at the right moment to produce the desired picture.

If the camera does not have synchronization contacts and if the ambient light is low enough, the shutter may be opened manually and the firing signal given by means of an accessory pushbutton switch connected to the shutter synchronization jack on the Flash Delay. Then the next input pulse to the Flash Delay will fire the Strobotac, with a delay as preset by the DELAY control.

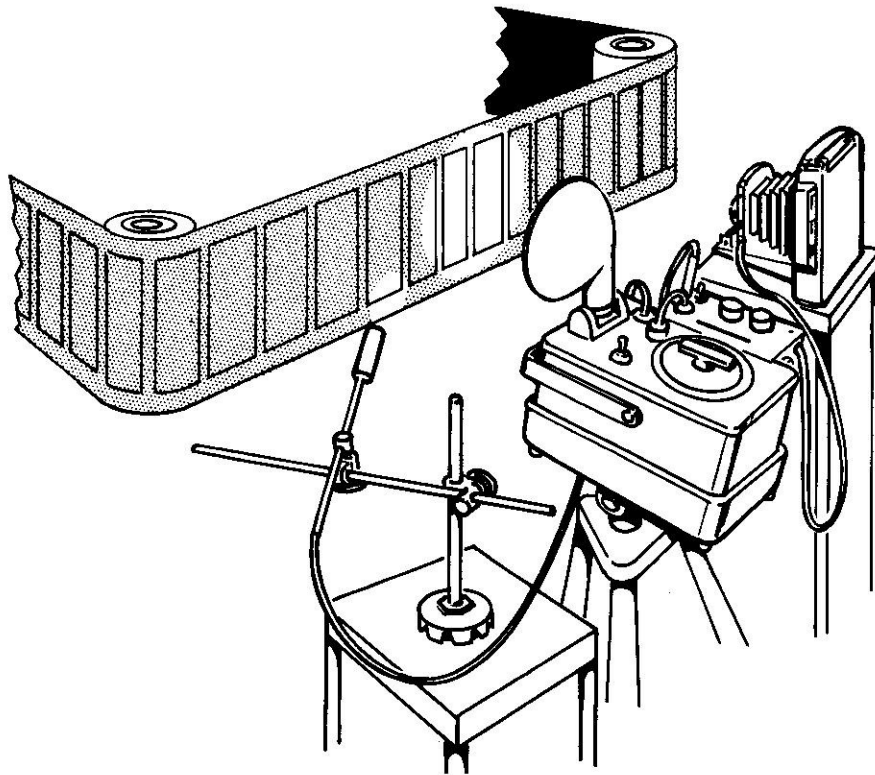

Figure 5-3. With flash delay set to MULT and Strobotac photoelectrically synchronized with roll labels, photographer adjusts delay for desired picture. He then switches flash delay to SINGLE FLASH, after which the tripping of the camera shutter will cause one flash to be generated at the right moment for the picture.

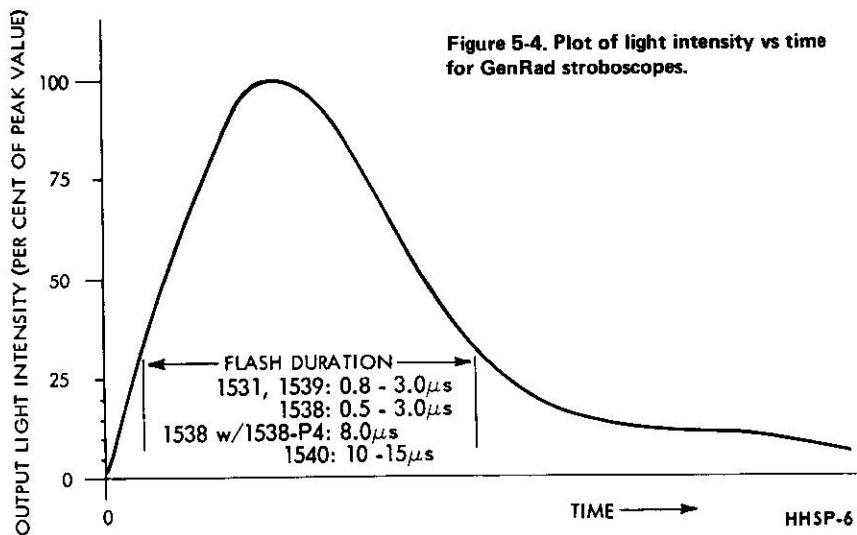

Figure 5-4. Plot of light intensity vs time for GenRad stroboscopes.

5.5 CHARACTERISTICS OF THE STROBOSCOPIC FLASH

5.5.1 Flash Duration

The duration of the stroboscope flash can be from 0.5 to 15 microseconds, depending on flash rate setting. (The duration is measured between 1/3-peak-intensity points.) Figure 5-4 shows a plot of the light intensity versus time. Note the low-intensity afterglow, or flash "tail," which occurs outside the 1/3-peak-intensity limit.

5.5.2 Flash Beam Width

With the standard reflector in place, the light output of a Strobotac is concentrated into a 10-degree beam (measured at 1/2-peak-intensity points), whose apparent source is 18 inches behind the front of the reflector. Outside this 10-degree cone, light intensity falls off sharply, so that the area of reasonably constant illumination is not large. If this beam width is not adequate to light the subject, the reflector can be easily removed and the bare flash lamp used to illuminate the area.

When the 1538-P4 High-Intensity-Flash Capacitor is used with the 1538-A Strobotac to produce extra-bright single flashes, duration is increased to 8 microseconds.

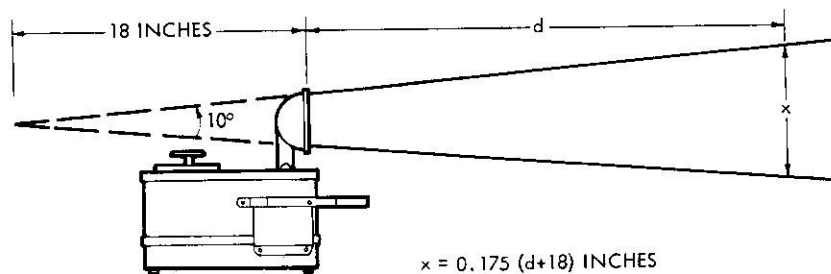

Figure 5-5. Beam width characteristics of Strobotac and Stroboslave with reflector in place.

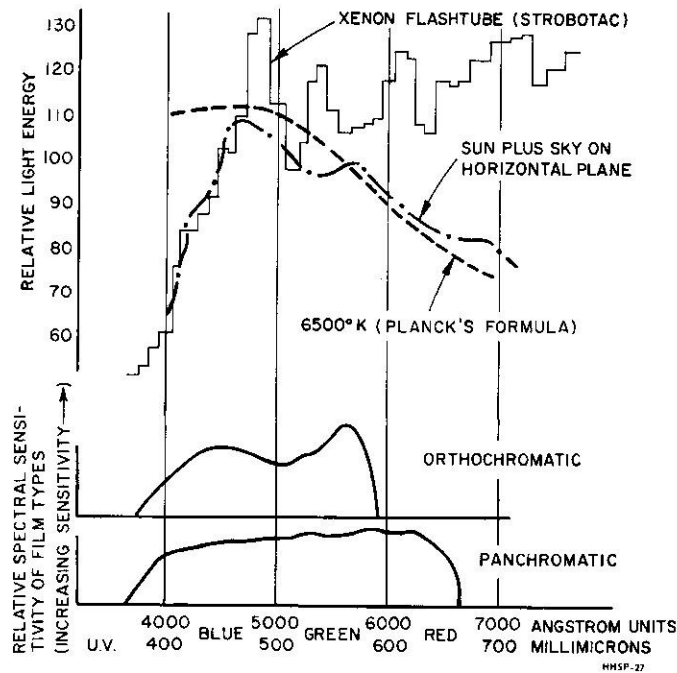

Figure 5-6. Spectral distribution of light output from GenRad stroboscopes.

5.5.3 Spectral Characteristics

The spectral distribution of the Strobotac flash (see Figure 5-6) is excellent for photography with both orthochromatic and panchromatic films. Equivalent color temperature of the flash is about 6500 to 7000 degrees Kelvin.

5.6 MULTIPLE-IMAGE PHOTOGRAPHS

Multiple-image photographs can be taken with either stationary or moving film. The procedure for making multiple exposures with stationary film is similar to that for single-flash photography. Multiple photographs by means of moving film require the use of motion-picture cameras that can transport the film at the desired speed. The motion-picture camera shutter is either locked open or removed entirely.

5.7 EXPOSURE DATA

Figure 5-7 can be used to determine guide number, given film speed and the type of GenRad stroboscope being used. To determine the effective lens aperture (f /setting), divide the guide number by the strobe-to-subject distance (in feet) plus 1.5. If the camera is placed close to the subject, the f /setting computed from Figure 5-7 should be multiplied by a K factor determined from Figure 5-8.

A second guide-number correction is required if the exposure is to be made with the stroboscope flashing repetitively at a rate above 100 flashes per minute. This correction factor is given for the four GenRad stroboscopes in Figure 5-9.

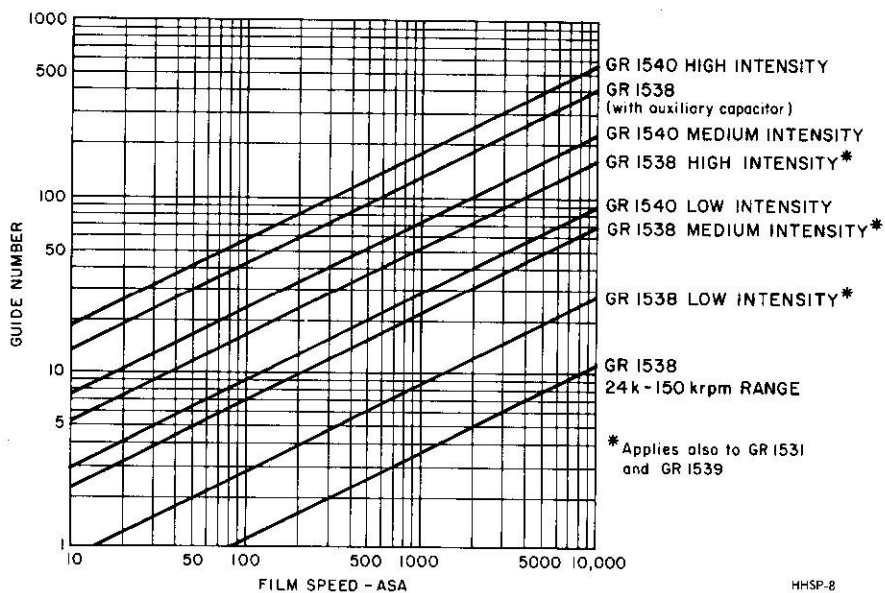

Figure 5-7. Guide number vs film speed for various GenRad strobes. Data are for single-flash operation.

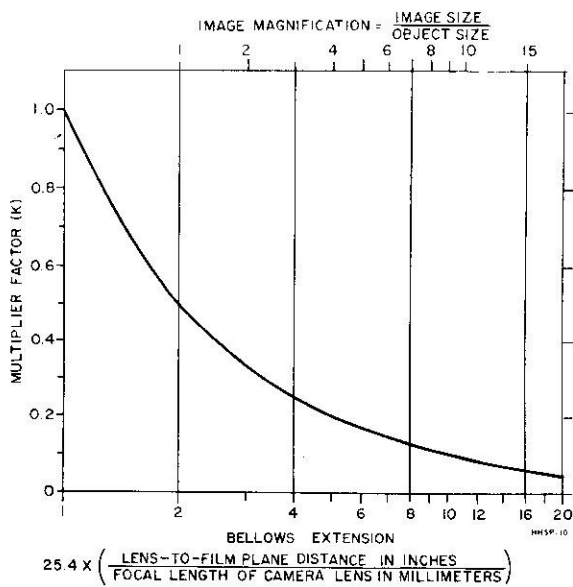

Figure 5-8. Multiplier to be applied to f/setting when camera is close to subject. Bellows extension = 25.4 lens-to-film-plane distance in inches/focal length of lens in millimeters.

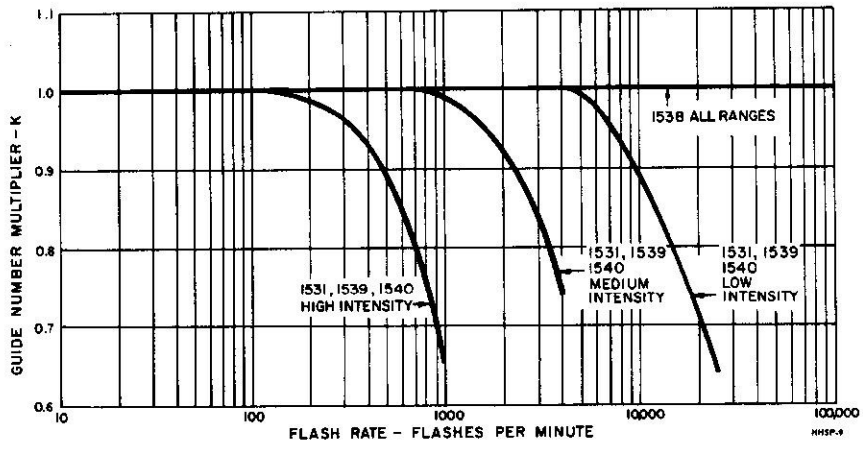

Figure 5-9. Guide-number correction for repetitive flashing.

Applications

6.1 GENERAL

No book, no matter how large, could offer a complete catalog of stroboscope applications. There are too many, and the number grows every day. We can, however, describe some of those that have come to our attention, in the hope that they may be used, extended, or modified to serve the purposes of the reader. Even in the matter of description we must ask indulgence; many of the applications are in fields alien to us, and in such cases we can merely pass along the details as they were given to us.

Future editions of this handbook will, we hope, reflect the interest of you, the reader, in sharing your experiences with the stroboscope. We will be grateful for and will respond personally to all communications on the subject.

Stroboscope applications could be classified in any of several ways: by the nature of the organization using the stroboscope (education, automotive industry, etc), by the type of activity involved (research, engineering, service), by the nature of the device being observed (fluids, fans, motors, etc), or by the technique used (speed measurement, slow-motion observation, photography, etc). No one of these methods is clearly superior to the others, and we therefore rely chiefly on an index to guide the reader to the applications in which he is most interested.

INDEX TO APPLICATIONS

- Air currents 18
- Belt tension 10
- Bottling 31
- Camera shutter speed 24
- Cavitation 17
- Closed-circuit television 23
- Color combination 5
- Dynamic balancing 21
- Dynamic models 33
- Educational applications 1-6,
8, 26, 27, 33, 37
- Eye research 14, 37
- Fans 18
- Flutter 30
- Fuel spray 32
- Glass fracture 37
- Gravity demonstration 1
- Horsepower measurement 10
- Kepler's second law 6
- Lead-shot observation 11
- Light-pulse generator 25
- Light velocity 2
- Loudspeaker studies 3
- Medical applications 14, 28,
30, 37
- Meter ballistics 19
- Milk-drop experiment 7
- Packaging 29, 31
- Photoelastic studies 34
- Photographic applications 1, 6, 17,
22, 24, 26, 27, 36, 37
- Physics demonstrations 1, 2, 6, 8
- Physiological applications 28
- Polariscope 34
- Printing 12, 29
- Projectile velocity 22
- Psychological applications 28
- Railroad application 36
- Ripple tank 26
- Roll-label inspection 29
- Saw blade 37
- Shadowgraphs 27
- Slip measurements 13
- Stage effects 37
- Standing waves 8
- Steel mills 37
- Stroboscope principles 4
- Tachometer calibration 9
- Tachometry, precise 35
- Tape recorder 37
- Television 23, 37
- Textile applications 15
- Torquemeter 16
- Velocity, light 2
- Velocity, projectile 22
- Vibration measurement 20, 37

1. Acceleration of Freely Falling Object

A ball is dropped so that it falls alongside a uniformly calibrated scale. During its fall the ball is photographed by the light of the stroboscope, flashing at a constant rate. The result is a multiple-image photograph in which the ball is shown at fixed time intervals on the way down. The widening gaps between images as the ball drops prove the rule of constant acceleration.

Equipment used: Strobotac stroboscope, calibrated scale and mount, Polaroid camera with Polaroid Type 46-L transparency film. The transparency is projected for class analysis within two minutes after exposure.

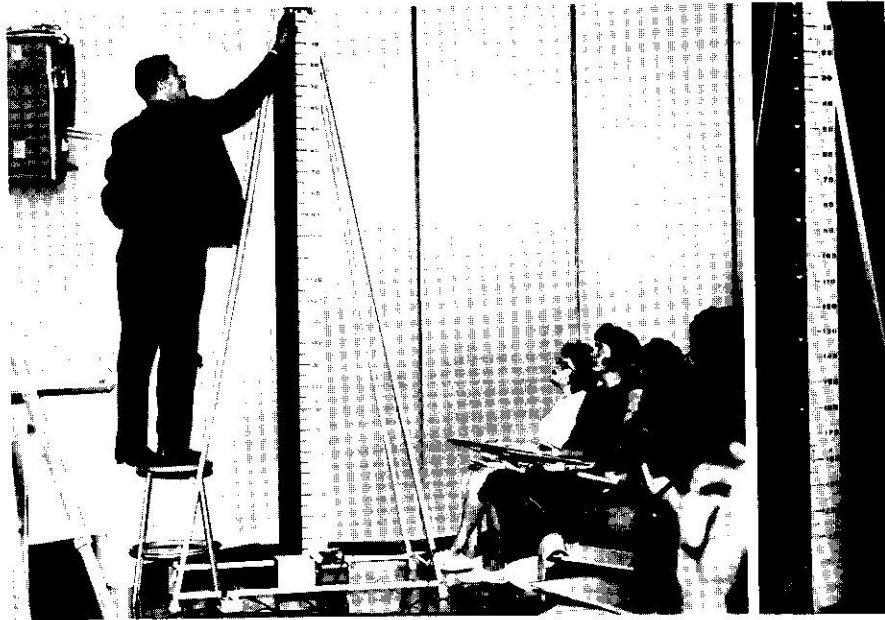

Figure 6-1. Ball is dropped alongside calibrated scale while camera takes multiple-image photo by light of Strobotac (at bottom of scale). Resulting photo (right) is proof of acceleration.

2. Finite Velocity of Light

A Strobotac stroboscope is aimed at a reflector at least 200 feet away. (In one experiment, a long corridor was used, in another, nighttime experiment, the light brick wall of a nearby building served as the reflector.) The flashing rate dial is set on the HIGH range where the flash duration is less than one microsecond. The Strobotac is fired (single-flash), and some of its light output produces a signal in a photomultiplier located adjacent to the Strobotac. Light reflected back from the reflector produces a second signal in the photomultiplier. The two signals are fed to an oscilloscope with a 0.2-microsecond-per-centimeter scale. Two peaks are clearly seen, the first from the Strobotac directly, the second after the beam has made the round trip to and from the reflector. With the reflector placed 250 feet away, the two peaks are seen about 0.5 microsecond apart on the oscilloscope.

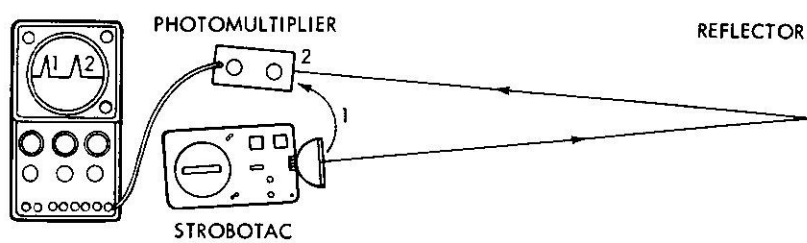

Figure 6-2. Light reaching photomultiplier directly from Strobotac and reflected from wall causes two distinct pulses on oscilloscope, proving finite velocity of light.

Equipment used: Strobotac, reflector, oscilloscope, photomultiplier. For noise-free trace, turn off fluorescent lamps in the area.

3. Loudspeaker Studies

A loudspeaker is driven by an audio oscillator, which also drives a Strobotac through a frequency divider. The divider steps down the frequency to the flashing-rate range of the Strobotac, but keeps the harmonic relation necessary for stroboscopic observation. As the oscillator frequency is varied, the observer can see the effects on the speaker cone. The flashing rate is automatically kept in harmonic synchronism with the speaker.

The Flash Delay can also be used as the frequency divider in this setup. It will, in fact, divide frequency any time its delay is adjusted to a point greater than the period between cycles of the input frequency. The Flash Delay also allows the observer to vary delay and thus watch the speaker throughout an entire cycle.

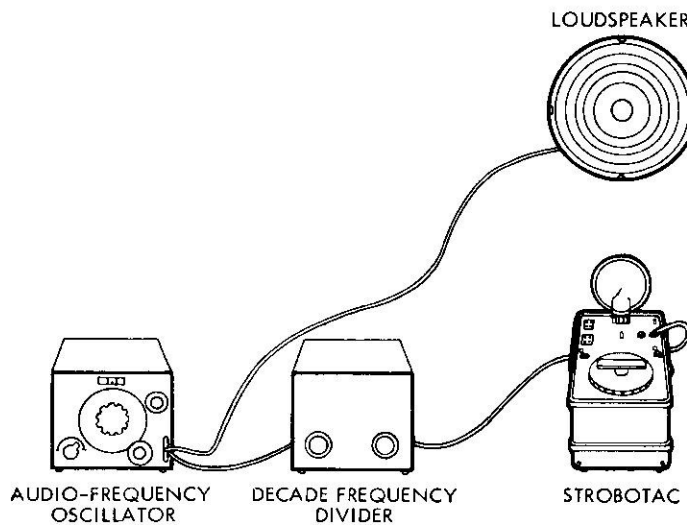

Figure 6-3. Interconnection diagram for driving Strobotac and speaker from same source.



Figure 6-4. Engineer studies speaker cone under microscope while adjusting flash delay to divide oscillator output frequency down to stroboscope range.

In another application involving the use of the stroboscope in loudspeaker development studies, finely shredded rayon flock is applied on a radial line of glue along the surface of a hemispherical loudspeaker. The Strobotac is flashed at a rate differing slightly from an integral submultiple of the frequency of the driving oscillator, whereupon nodal points and the degree of vibration of the diaphragm can be determined by examination of the free ends of the flock. Radiator breakup and other irregularities are readily observed.

In all loudspeaker studies, a magnifying glass or microscope is an important accessory.

4. Principle of the Stroboscope

Of course, the basic classroom experiment using the stroboscope should be a demonstration of the stroboscopé itself. The student should first be made familiar with the basic principles of the stroboscopic illusion. Then he should be taught the following rules for correct use of the stroboscope:

1. Always know exactly what the object looks like when it is stationary before trying to find stroboscopic images.

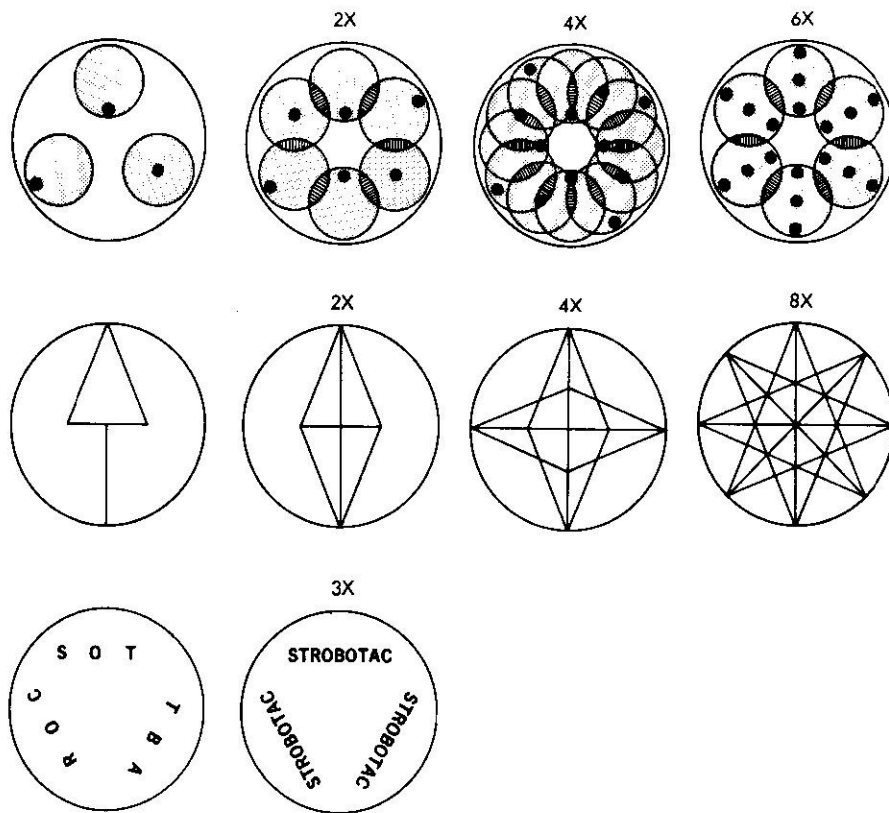

Figure 6-5. Classroom interest can be aroused by strobe disks designed to produce special effects. The three disks at the left take on the appearances shown when viewed under strobe light flashing at the harmonics indicated. The possibilities are unlimited for the creative teacher.

2. If the object is symmetrical, introduce asymmetry by a crayon or pencil mark, if possible.
3. At least **two** stopped-motion images must be obtained for speed measurement.
4. In tachometry, one should always begin high and work down to find the true stopped image.

An ordinary four-bladed fan is all that is needed for an effective demonstration of the tachometric and motion-observation capabilities of the stroboscope. A simple speed measurement of an unmarked, four-bladed fan is sure to introduce the student to the great number of false images that can be obtained, and a subsequent measurement with one of the blades marked with a crayon will convince him of the usefulness of this technique.

Of course, the innovative teacher can devise problem disks or disks with special effects to attract attention. Or the students themselves may be encouraged to create stroboscopic disks.

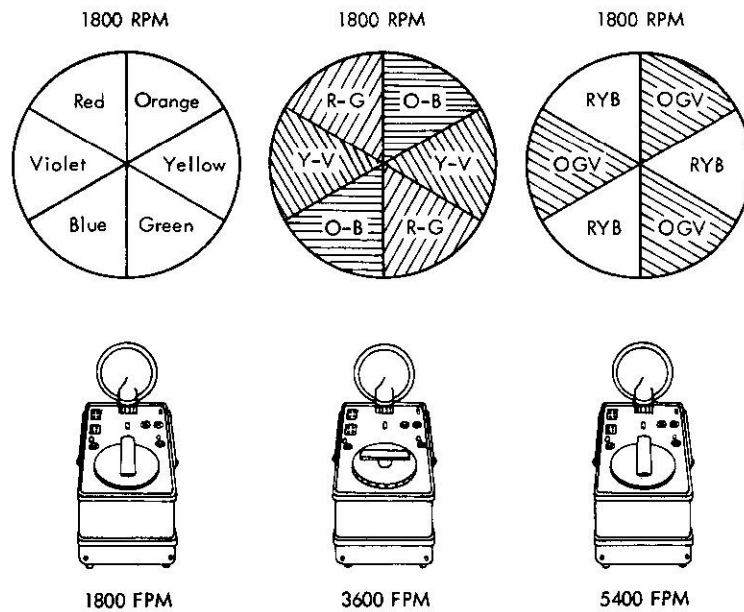

Figure 6-6. The stroboscope, flashing at harmonics of the disk speed, combines colors. For a spectral plot of the xenon flash, see Figure 5-6.

5. Effects of Combining Colors

Many stroboscope demonstrations have been built around the use of specially designed disks mounted on shafts driven by variable-speed motors. One such demonstration involves the mixing of colors. A disk is divided into six 60-degree segments, each painted a different color. Suppose the colors are red, orange, yellow, green, blue, and violet, arranged as shown in the drawing. Then, with the Strobotac flashing at twice the speed of the disk, three combinations of two colors may be seen: orange-blue, violet-yellow, and red-green. If the Strobotac is set to flash at three times the disk speed, the observer sees two combinations of three colors: orange-green-violet and yellow-blue-red. Obviously, many variations on this technique can be devised. The disk speed can be varied to demonstrate the persistence of color vision. Ambient light should be kept to a minimum.

Enhancing the usefulness of the Strobotac in color studies, both visual and photographic, is the similarity of its light spectrum (see Figure 5-6) to that of daylight.

6. Demonstration of Kepler's Second Law

A golf ball is suspended by a string and is made to swing back and forth like a pendulum. A second force is then applied at a right angle to its path, so that it begins to describe an ellipse rather than a straight line. A Strobotac is set at a moderately slow flashing rate, and a Polaroid camera, shooting from either directly above or directly below the ellipse, is used to obtain a multiple-image photograph.

According to Kepler's second law, the string of the orbiting golf ball describes equal areas in equal times. Therefore, the photograph, with images produced at constant time intervals, will show the images spaced farther apart as the ball approaches the center of the ellipse, while the closer spacing at the longer radii demonstrates the slowing down of the golf ball as it gets farther away from the center.

7. Crown Effect of Splashing Milk Drop

Probably no stroboscope demonstration has received more attention than has the famous "milk-drop" effect. In the simplest form of this demonstration, the milk drop is photographed at successively later points during its descent and as it splashes on a black metal plate. The results are as shown in the accompanying pictures, which are all single-image photographs.

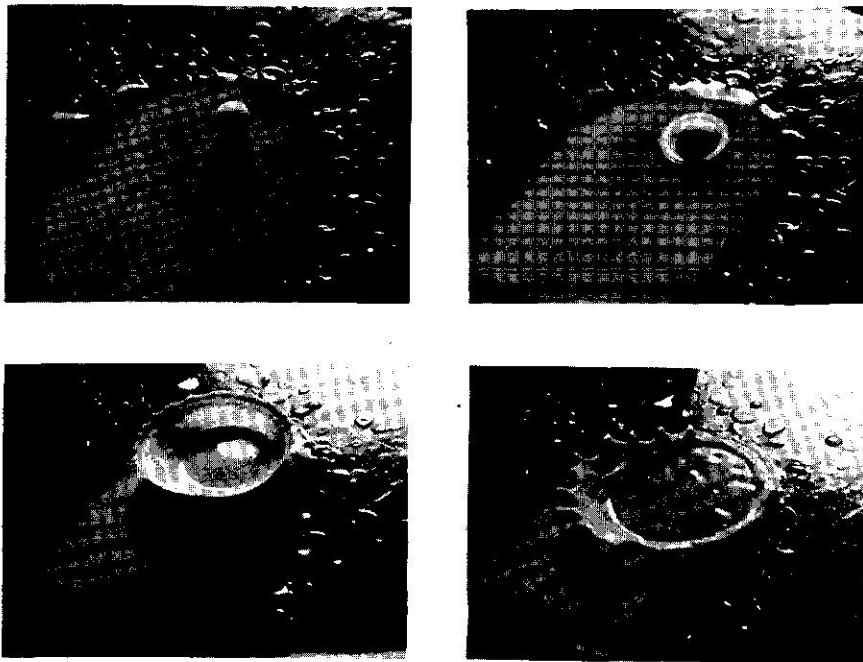

Figure 6-7. The famous "milk-drop" photographs.

A more ingenious exhibit, and one that involves no photography, calls for two Strobotac accessories: The 1536-A Photoelectric Pickoff and the 1531-P2 Flash Delay. The pickoff is mounted about six inches above the splash plate and aimed so that light is reflected from the falling drops to trigger the photocell. The pickoff is connected to a Strobotac or Stroboslave via the flash-delay unit. With delay set at minimum, the stroboscope flashes virtually at the moment the drop passes the photocell; because of the brief flash duration, the drop is seen clearly. As the delay control is advanced slowly, drops are seen at later stages of their descent, and it is easy to set the delay so that the flash occurs during impact, so that the crown pattern is visible.

If the drop path is backed by a black semienclosure, the effect is heightened. A white silicone solution is recommended for the "milk," and this can be received in a container at the base and pumped back to the dropper for a continuous display. Tilt the splash plate slightly toward the observer.

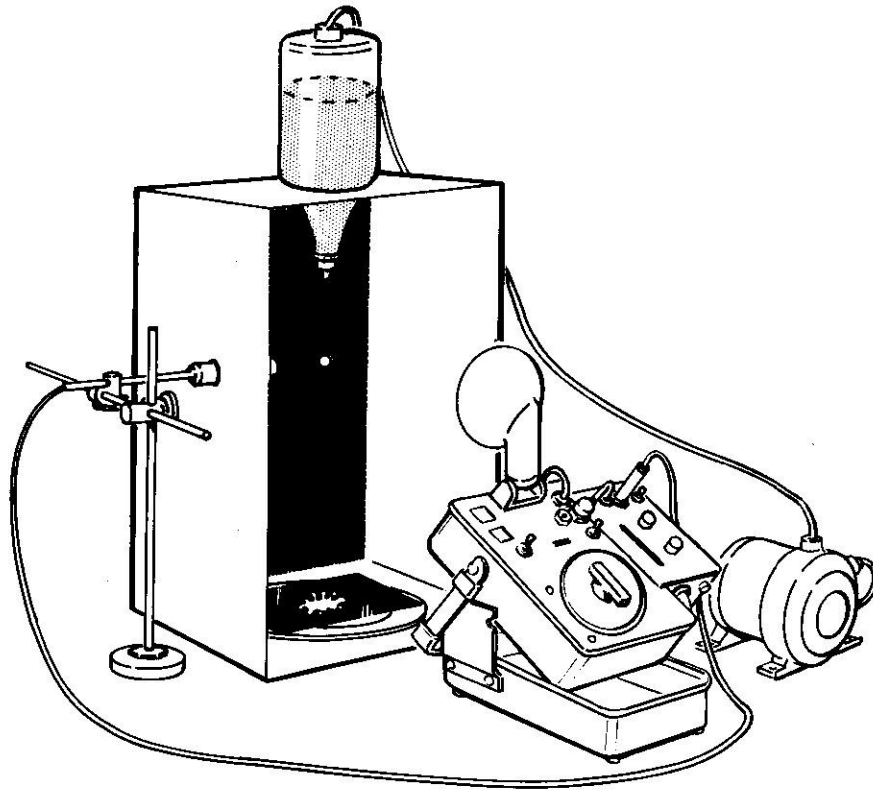

Figure 6-8. The drop can be "stopped" visually as well as photographically, by means of a setup such as shown above. Photoelectric pickoff senses light reflected by drop, triggers Strobotac. Flash delay is adjusted to catch drop at any point from pickoff to splash plate.

8. Standing Waves in an Elastic Band

An elastic band stretched tight and plucked makes another interesting stroboscope study. Take, for instance, a wooden box, blacken the inside, and fasten the ends of a cut rubber band through holes in opposite ends of the box. The result is a ready-made stage for demonstrations of standing waves, secondary resonances, etc.

For a more dramatic presentation, use a piece of rubber clothesline sprayed with fluorescent paint and excite it by means of a motor-driven cam near one end. A camera is a useful accessory in the analysis of such string vibration.

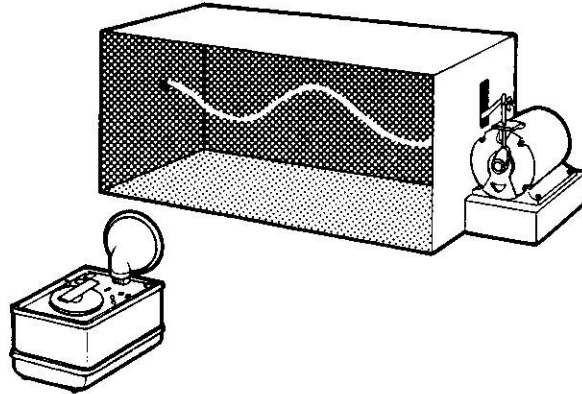

Figure 6-9. Rubber clothesline, vibrated as shown above, can be used to demonstrate standing-wave phenomena.

9. Tachometer Calibration

Engine tachometers can be calibrated with the Strobotac to an accuracy even better than the $\pm 1\%$ nominal accuracy of the instrument. The technique involved makes use of (a) the absolute accuracy of the Strobotac when it is set to power-line frequency and (b) a disk specially designed to permit tachometer calibration at various speeds while the Strobotac is held at the power-line frequency.

The stroboscopic disk of Figure 6-10 can be cut out and mounted on light cardboard or metal. The center should be carefully located and drilled to fit on the drive shaft, the free-end shaft extension of the drive motor, or on a dummy tachometer plugged into one of the positions on a multiple-unit tachometer test stand.

With the Strobotac set to flash at line frequency, as the speed of the test stand motor increases, the rings of the disk will appear successively to stand still. The outside ring will appear motionless at each even hundred rpm on the tachometer scale. The actual speed, in hundreds of rpm, will be readable intermittently by stroboscopic combination of the outside ring figures.

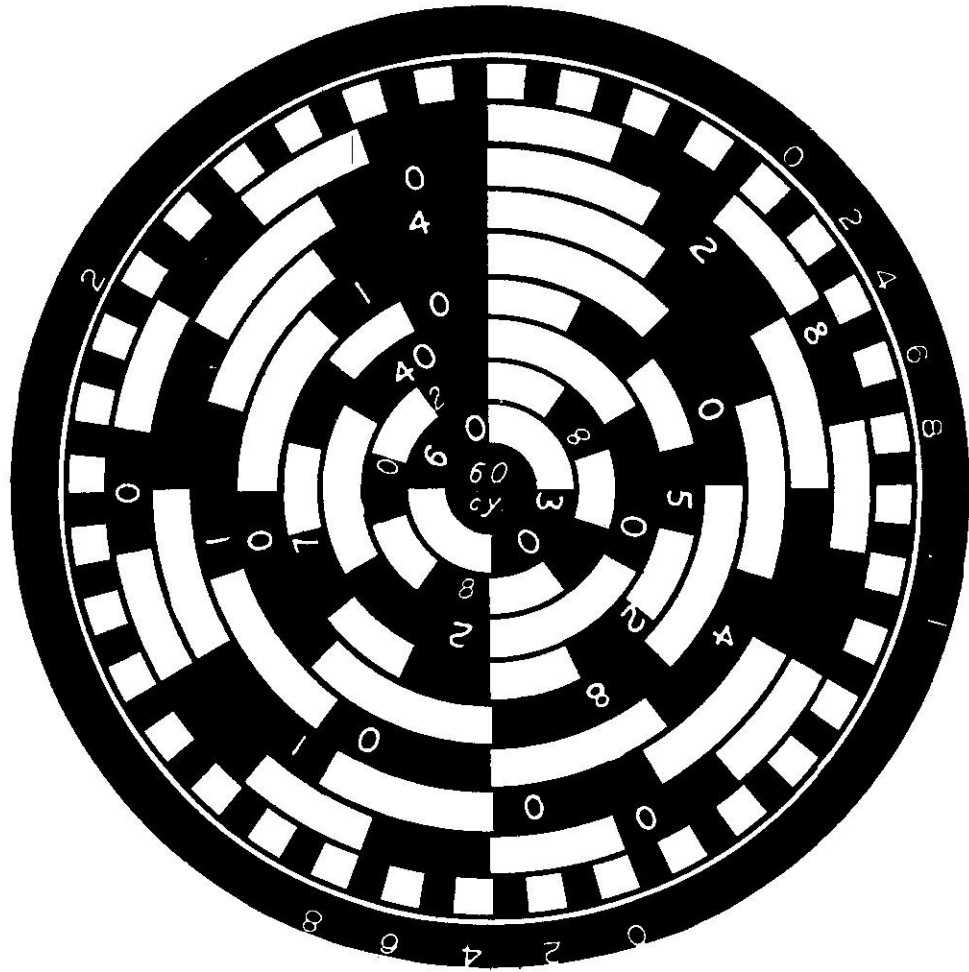

Figure 6-10. Tachometer test disk.

10. Determining Belt Tension and Horsepower

Dr. Hans-Heinz Oehmen, in a paper¹ published in 1962, showed that the tension of a belt is related to its vibrating frequency. If the belt is at rest, vibration can be introduced by a light blow. Whether thus excited or in normal operation driving a pulley, a belt can be observed stroboscopically and its vibrating frequency measured.

Other factors entering into the frequency-tension relationship are a constant (K) depending on properties of the belt itself, the length of free belt between pulleys, and the width of the belt. The equation is:

$$T = Kf^2 L^2 w$$

where

T = belt tension
K = belt constant
f = vibrating frequency
L = length of free belt
w = width of belt

When the tensions in the tight and slack sides of a belt drive have been calculated, it is a simple matter to calculate horsepower. The relationship is:

$$hp = \frac{KL^2 w^2 V}{33,000} (f_t^2 - f_s^2) = \frac{(T_t - T_s)V}{33,000}$$

where

T_t = tension (in pounds) of tight side
T_s = tension (in pounds) of slack side
V = belt speed in feet per minute

11. Inspection of Lead Shot in Shot Tower

Lead shot, ball bearings, and other spherical objects are commonly formed as they are in free fall and while changing from a molten to a solid state. In the research facility of such a manufacturing operation, molten lead is poured into a cast-iron frying pan with small holes drilled in the bottom. The frying pan is vibrated vertically by alternating-current magnets, so that the vibrating frequency is related to the power-line frequency.

A Strobotac is positioned to throw a horizontal beam about 10 inches below the frying pan. Lead dropping from the holes in the frying pan is observed in silhouette — that is, with the viewer looking at the Strobotac as the drop passes between him and the light. With the dropping rate controlled by the power-line frequency, the Strobotac can also be set to LINE flashing rate for close observation of the shape and size of drops.

¹Dr. Hans-Heinz Oehmen, *Braunkohle Waerme und Energie*, Vol. 14, No. 10, 1962.

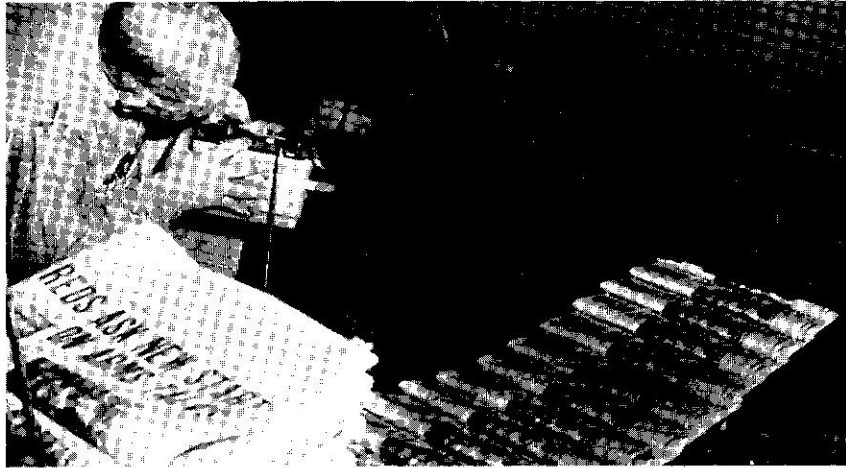

Figure 6-11. Strobotac is widely used to check press operation, color registration, etc. The faster the press operates, the more effective the Strobotac.

12. Printing Applications

The Strobotac is widely used in the printing industry as a means of checking registration while presses are running. A manufacturer of gift-wrap paper has increased the production speed of a four-color rotogravure press to 450-500 feet per minute, twice that practical without the stroboscope. One operator and his assistant can run this rotogravure press while periodically checking color registration with the Strobotac. Stroboscopic observations indicate not only which color is off register, but also the degree of correction required.

The combination of photoelectric pickoff and time-delay unit can be used to good advantage in many printing applications. The pickup can be stationed to detect passage of some reflective area, with the time-delay used to adjust the point of observation. The stroboscope can then be the compact, inexpensive Stroboslave, which can be permanently mounted at the press for continuous automatic monitoring.

13. Slip Measurements Between Two Shafts

The amount of slip between two shafts can easily be measured by the use of Strobotac and photoelectric pickoff. A piece of reflective tape is affixed to one shaft and the pickoff is positioned to detect it. With the Strobotac or Stroboslave thus synchronized to one shaft, its light is used to observe the other shaft. A reference mark on the second shaft is observed, and the amount of slip is directly indicated by the rate of rotation of this reference mark (see Figure 3-3).

This technique can be extended to cases where one shaft is moving at two or more times the speed of the other. Here several pieces of reflective tape (the number corresponding to the speed ratio) are evenly spaced around the lower-speed shaft, so that once again the actual slippage is indicated directly by the apparent motion of the reference mark.

14. Eye Research

The Strobotac has been widely used in qualitative laboratory investigations regarding the behavior of the eye. In one application, the object was to determine whether there was vision during eye movement. The subject's eye was connected to the measuring system with four silver electrodes, so that eye movement was used to trigger the Strobotac. With the room darkened, the subject was asked to read various headlines. The only illumination was the brief flashes of the Strobotac, occurring only during eye movement.

The Stroboslave would have proved equally satisfactory in this application.



Figure 6-12. Medical research has many uses for the Strobotac. In above experiment, strobe helps researchers study eye behavior.

15. Textile Applications

Many articles have been written on the use of the stroboscope in the textile plant, and few such operations are not already very familiar with the stroboscope. A complete list of textile applications would amount to a catalog of textile machinery. Some of the more common, however, are listed below.

Speed checks on buckets, spindles, travelers, shafts, cylinders (spoolers).

Observation of gain and loss motion of bobbin drives on roving frames.

Checking guide rollers or wet spinners, ballooning, twist, and shuttles.

Detection of filling slubs in enameling duck.

Studies of endless check straps.

Detection of the following faults:

- slack bands and tapes
- spindles that need oiling
- crooked idlers
- chokes in idlers
- chokes under spindles
- chokes on bolster
- chokes on spindle clutch
- chokes in bobbins
- spindles out of plumb
- worn spindles
- crooked bobbins
- bad rings
- bad or worn travelers
- ring rail not level
- band and tape out of whorl
- thread in whorl
- excessive band and tape slippage
- split bobbins
- worn bobbins
- uneven yarn
- mixed yarn
- oily yarn
- slippage of belts and tapes

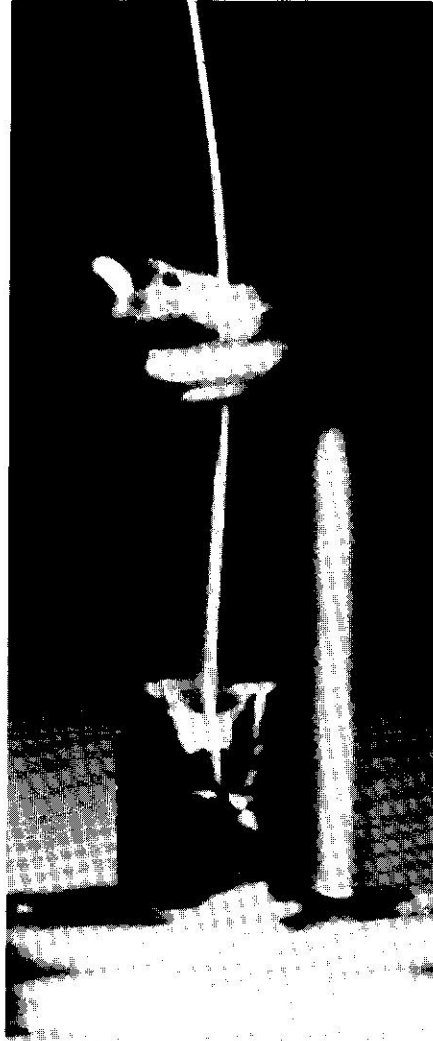

Figure 6-13a. The 3/16"-diameter spindle of a "false-twist" textile machine. Speed: 250,000 rpm.

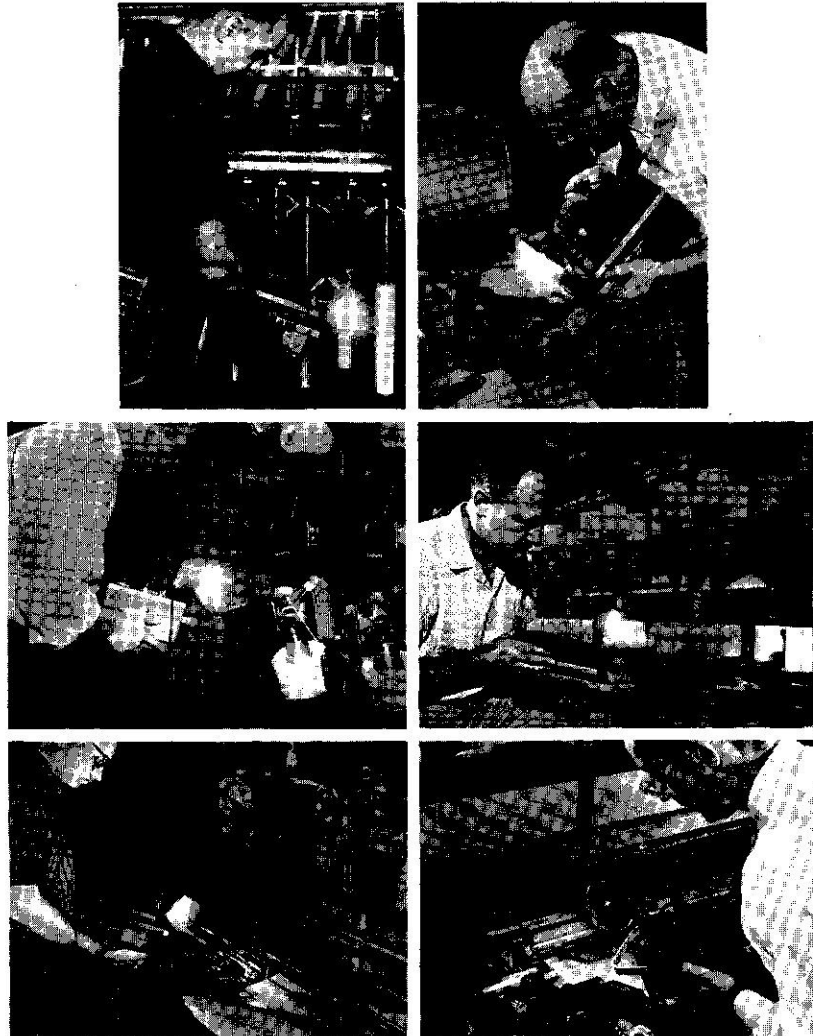

Figure 6-13b. The stroboscope is standard equipment in most textile plants.

16. A Simple Stroboscopic Torquemeter

If two shafts are connected by an elastic coupling and if the rotational motion is "stopped" by the stroboscope, the position of a pointer on the spring coupling will change as the driven shaft is loaded. The addition of a scale permits measurement of torque.

This principle is used by a manufacturer of tachometers to measure the power dissipated in the tachometer gears. A brass tube about 15 inches long is coupled to the motor shaft at one end and through a bearing to a drum-type dial at the other. Within the tube is a straight length of 0.037-inch steel piano wire, rigidly attached at the motor end and fixed at the other end to a small shaft that turns freely in a bearing within the end of the tube. This shaft carries a small drum with an index mark on its periphery to indicate angular displacement against the scale on the adjacent dial attached to the brass tube. The short shaft then passes through the outer bearing and a coupling to the rotating member on which power loss is to be measured. Therefore, when the motor is stationary, manual rotation of the output coupling shaft twists the piano wire and causes the index dial to rotate. Stop pins limit the excursion of the index dial to 180 degrees with respect to the other dial.

When the motor is started, the acceleration puts a high torque on the wire. The load is driven directly, because of the stop pins, during startup and stopping. Under running conditions, however, the Strobotac is adjusted to give a stationary image of the dials, and the position of the index with respect to the dial marked in degrees of arc is readily observed.

This torsion meter is easily calibrated by comparison of applied torques on the output shaft to resulting dial reading with the shafts at rest. The results should yield a linear curve. Power, as the product of speed and torque, can then be easily calculated.

This equipment has been used to measure power losses as small as 0.003 horsepower at speeds of 600 rpm, with an accuracy of $\pm 5\%$. With smaller equipment and finer wire, the technique should be useful for measuring very much smaller amounts of power.

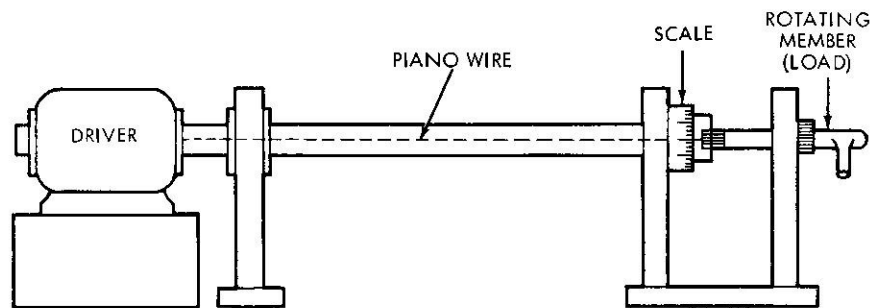

Figure 6-14. When load is driven by motor at left, torque is indicated by amount of twist in piano wire. Scale can be calibrated to indicate torque directly.

17. Cavitation Studies

Cavitation, the forming and collapse of air pockets against the blades of a turbine or other hydraulic machine, represents a serious problem for designers of such equipment. The best method of avoiding the pitting damage caused by cavitation is preliminary reinforcement of the areas where cavitation damage is likely to occur. Unfortunately, so many widely divergent factors are involved (number of blades, blade pitch, speed, head, etc), that an analytical appraisal is all but ruled out. The answer: stroboscopic observation of cavitation at work on an operating turbine.

A transparent window is installed in the turbine housing in such a way that it blends with the housing contours and thus does not introduce new variables. The stroboscope light must penetrate this window and the air-clouded water between it and the blades; therefore, the brightest possible stroboscope is called for. A 1538-A Strobotac with plug-in high-intensity-flash capacitor provides satisfactory illumination for single-flash photography.

To reduce the cloudiness resulting from entrained air, the entire system is subjected to high pressures where cavitation does not occur. Then pressure is rapidly reduced to the desired point of investigation and a photograph is taken with a single flash before the cloudiness becomes severe. The open-shutter technique is used, with the room kept in total darkness.

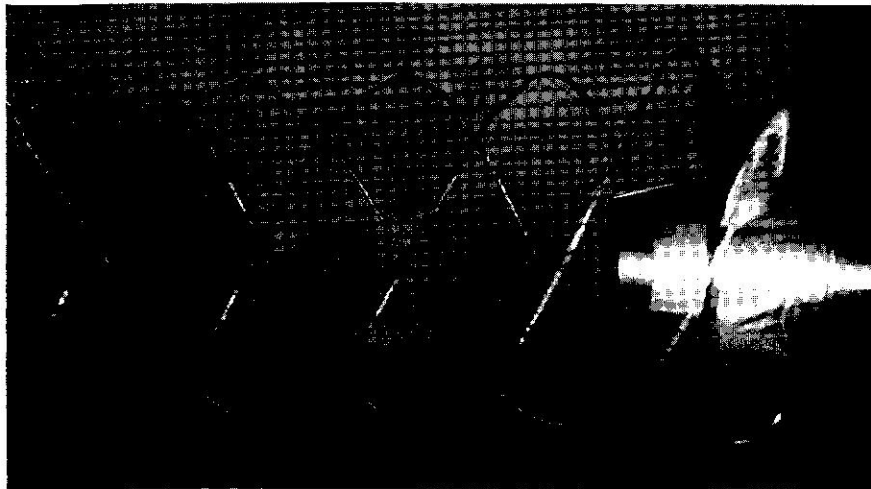

Figure 6-15. Propellers and their effects upon air or water make interesting subjects for the stroboscope.

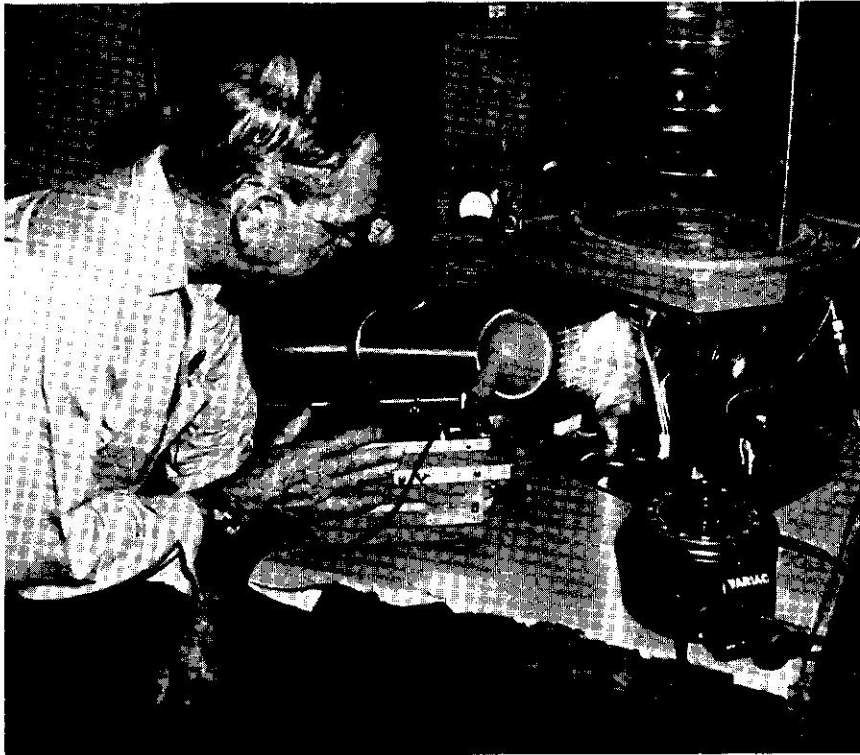

Figure 6-16. Technician uses Strobotac to troubleshoot cold-drink vending machine. Smoke can be added to trace flow of cooling air from the fan.

18. Fans and Air Currents

Fans, as noted earlier, make ideal subjects for stroboscopic study, a fact well known to most manufacturers of air moving equipment. Perhaps less widely appreciated is the usefulness of the stroboscope in the investigation of air currents produced by fans. Manufacturers of vending machines, for instance, have successfully used the Strobotac to ensure that cooling fans are adjusted to direct the cold air to the area where beverages or other food items are stored.

In the study of air currents, what is actually observed is not air, of course, but a chemical smoke or powder. Talcum powder and vapor from dry ice in water have been used satisfactorily for this purpose. So has titanium tetrachloride, although this is more difficult to control and may cause an acid reaction. One of the best smokes for this application is heated crystalline ammonium chloride.

The smoke may be examined visually under stroboscopic light to detect periodic air patterns or, better still, photographs can be taken for leisurely, detailed analysis. Such air-current photographs are shown in Figure 6-17.

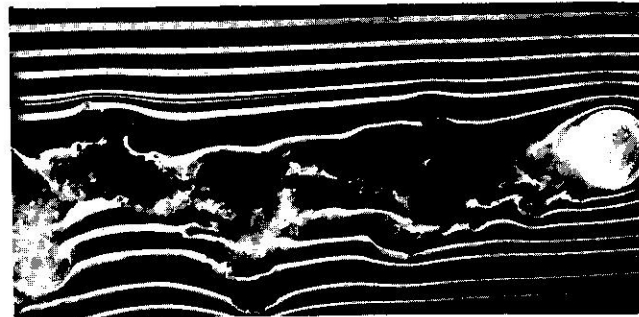
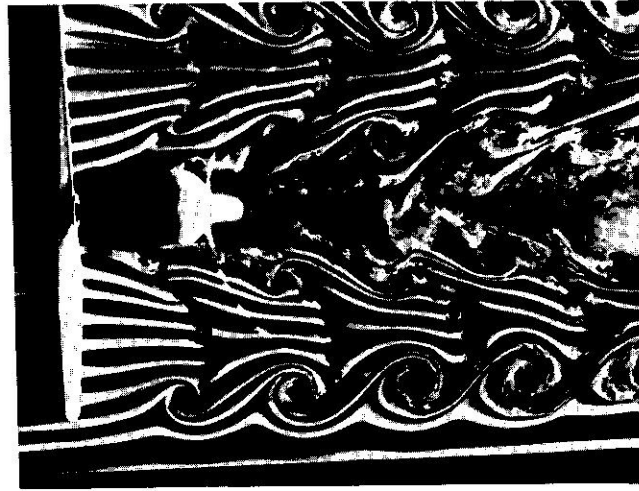
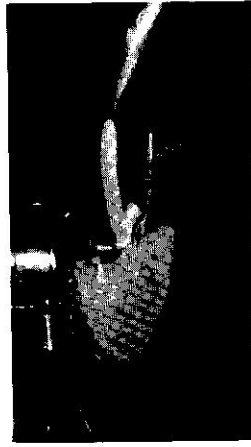

Figure 6-17. Chemical smoke vividly shows air currents caused by fan, propeller, baseball, all stroboscopically "stopped" for the camera.

19. Meter Ballistics Testing

The Strobotac has been used successfully to measure the time a meter pointer takes to rise to a specified point, the time it takes to fall when the terminals are short-circuited, and overshoot. The measurement setup includes, in addition to the stroboscope, a source of meter excitation and a time-delay generator.

The exciting voltage is applied to the meter and to the time-delay generator at the same time. The output from the time-delay generator is used to fire a Strobotac or Stroboslave. Therefore, the delay between the moment of excitation and the flash is accurately controlled by the time-delay generator. The excursion of the meter pointer can then be seen or photographed by the stroboscopic light. Deflection vs delay can then be plotted (see Figure 6-19) for a presentation of meter rise-time performance.

There are several variations to this method. A second time-delay generator can be used to measure fall time. Or, for ac testing, the GR 1396 Tone-Burst Generator can be used to produce signal bursts spaced so that the meter returns to rest after each burst.

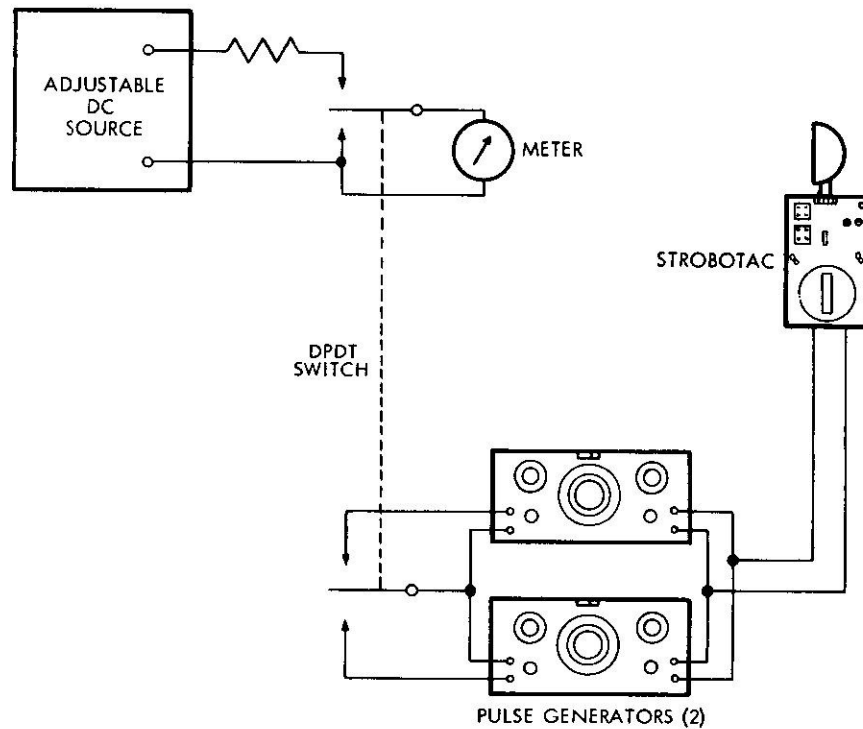

Figure 6-18. Setup used for meter-ballistics testing.

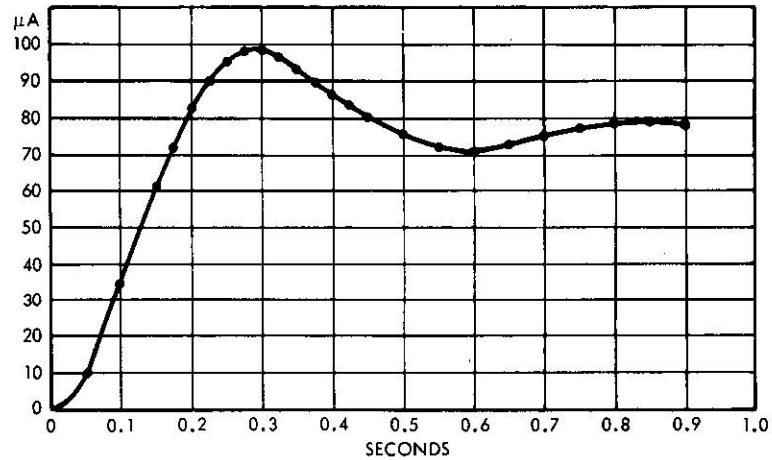

Figure 6-19. Meter deflection vs time, as measured by system shown in Figure 6-18.

The 1531-P2 Time-Delay Unit can be used to insert delay from 100 microseconds to 0.8 second; its delay control, however, is not calibrated.

20. Vibration Measurement

The stroboscope is especially valuable in vibration studies because vibration usually involves just the type of motion — rotating or reciprocating — that the stroboscope can optically stop or slow down. If the vibration is periodic, the stroboscope flashing rate need only be adjusted until the vibrating object appears to stop. The vibration frequency can then be read off the stroboscope dial (subject to the considerations regarding harmonics; refer to Chapter 3). The addition of an accurate distance scale and, if necessary, a microscope provides displacement information.

If the vibrating motion is not periodic, some means must be introduced to synchronize the flashing rate with the vibration. Any of the various photoelectric or mechanical pickoffs referred to in Chapter 2 can be used. Or a vibration pickup, used with a sound-level meter or vibration meter, can be used to send triggering impulses to the stroboscope. (The inexpensive Stroboslave can serve as the stroboscope where an external pickup is used for synchronization.) Of course, if one already has a vibration meter, the use of a stroboscope will add little in the way of quantitative measurements. However, the opportunity to see the vibration in slow or stopped motion, and before and after corrective measures are applied, is often much more useful than a simple measurement of acceleration or velocity. A filter should be used between the sound-level or vibration meter and the stroboscope. An octave-band or narrow-band analyzer can be used to provide such filtering.

Applications for the stroboscope in vibration measurement are many and diverse. The high-speed performance of fans, propellers, and other rotating devices can be studied stroboscopically. Sources of noise and vibration due to misadjustments, misalignment, and wear can be easily detected. The vibratory modes of turbine blades can be checked as they are driven electromagnetically, and the mode shapes observed

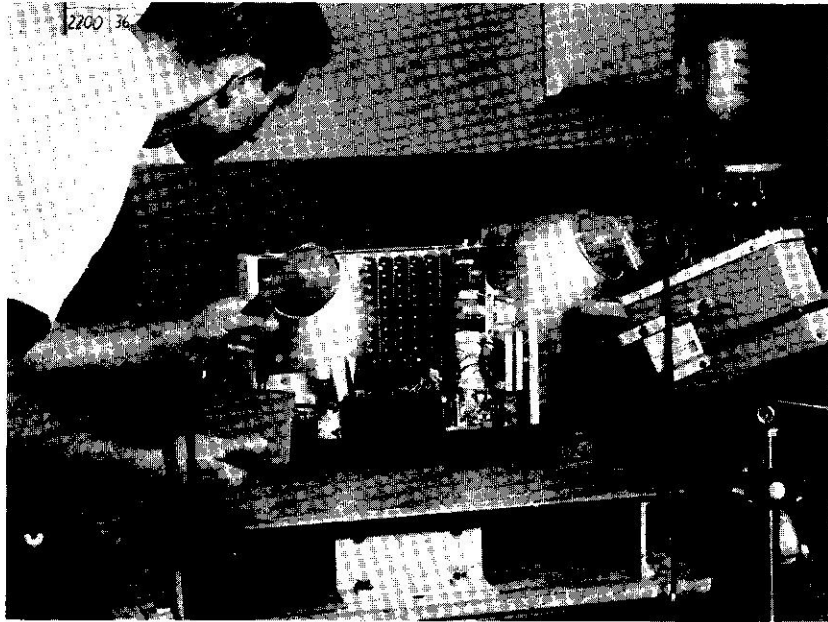

Figure 6-20. Electronic instrument on vibration shake table is studied under combined light of Strobotac and Stroboslave.

with the aid of an optical magnifier. The flapping of a helicopter's blades has similarly been studied by the light of a stroboscope.

The stroboscope can also be used to observe tests on a vibration shaker. If the flashing rate is slightly offset from the shaker frequency, the vibration is seen in slow motion. The motion can be studied and correct damping measures determined.

Another use of the stroboscope is the detection of critical or resonant speeds in rotating devices. By using the slow-motion effect, one can observe the behavior of a part during resonance, and can distinguish between fundamental and harmonic resonance.

For a further discussion of the stroboscope's role in vibration measurement, refer to the *Handbook of Noise Measurement*, available from GenRad at \$7.50 a copy.

21. Dynamic Balancing

Dynamic balancing of a shaft or other rotating device usually requires knowledge of (1) the amplitude of vibration and (2) the phase of the vibration with respect to the rotating motion. Both of these determinations can be made by means of stroboscopic illumination of the rotating device. Amplitude measurement, as has been noted, is essentially a matter of producing the slow-motion illusion so that the vibration can be clearly seen against a calibrated scale, perhaps with a magnifying glass or a microscope to improve resolution. (Of course, a vibration meter, if available, can also be used to measure amplitude.)

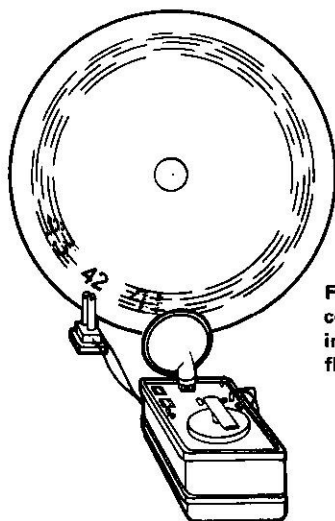

Figure 6-21. In this dynamic-balance setup, contacts are closed at point of maximum imbalance, which is revealed by the flashing Strobotac.

Determining the phase relation between the vibration and the rotation requires a slightly more elaborate setup, though even here the stroboscopic technique is much simpler than other methods. The setup shown in Figure 6-21 is by no means definitive, but it does illustrate the principles involved. A set of contacts connected to the INPUT jack on a 1538-A Strobotac or 1539-A Stroboslave are set to close at the point of maximum vibration amplitude. A simple bearing mounted on a stiff spring is used to keep the contacts apart except when they are closed by the vibration. A series of evenly spaced numbers is marked around the circumference of a flywheel or pulley attached to the shaft (or reference marks can be scribed around the shaft itself). Then, with the flashes occurring only at the "high spot" of vibration, the number corresponding to that angular position will be repetitively illuminated, indicating the position of the high spot.

Another method involves the use of a vibration pickup and analyzer to drive the stroboscope and graphical analysis to calculate the position and weight of the required counterbalance.

22. Measurement of Projectile Velocity

The velocity of a projectile can be quickly determined from a multiple-image photograph showing the projectile at known intervals of distance and time. The known time interval is simply the reciprocal of the stroboscope's flashing rate. If the stroboscope is flashing at a rate of 6000 per minute, then the flashes — and the exposures — occur $1/6000$ minute, or $1/100$ second, apart. The distance traveled between exposures can be determined from the known length of the projectile itself.

Figure 6-22 illustrates the effective use of multiple-image photographs to measure the speed of an arrow leaving a bow. The Strobotac was set to flash 100 times per second. Bands of white tape were placed on the arrow to provide distance calibration. It was an easy matter, then, to determine how far the arrow traveled during $1/100$ second, the time between successive flashes, and thus to compute the "muzzle velocity" of the bow.

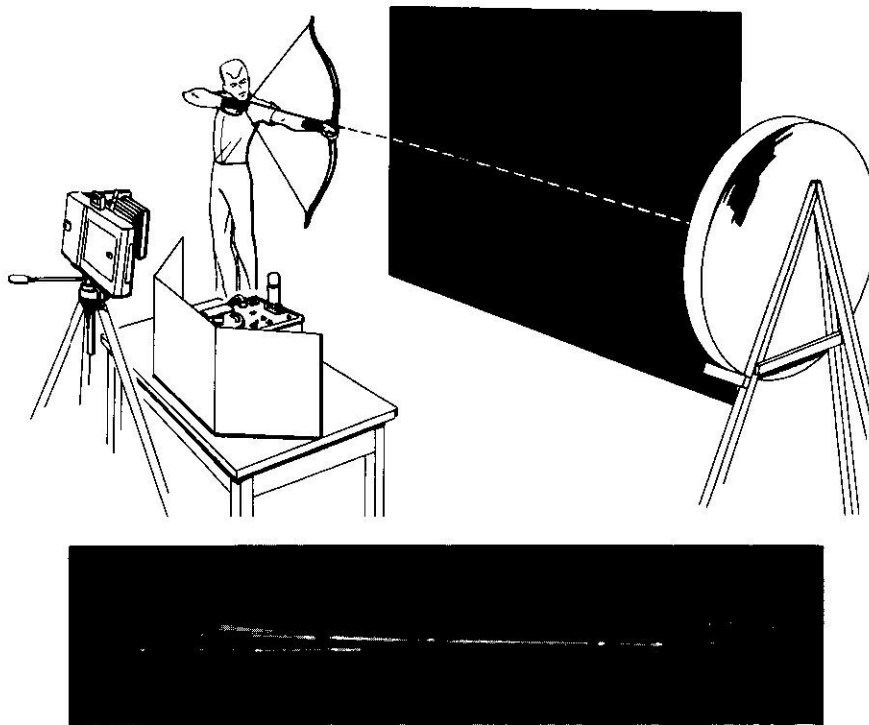

Figure 6-22. Setup for photographing arrow in flight. Bands of tape on arrow (see inset) permit easy calculation of distance traveled between flashes, thence velocity.

In a related application, the Strobotac has been used to measure the terminal velocity of a pile-driver, with this figure then used in calculations to determine the energy of the drive. Multiple-flash photographs were taken, as above, with the pile driver marked to provide a distance calibration.

23. The Stroboscope and Closed-Circuit TV

A closed-circuit television system can be used for remote stroboscopic observation and is so used to remove the human observer from danger or annoyance. At a British propeller plant, for instance, a closed-circuit television setup was used to observe the testing of variable-pitch ejectable propellers. The stroboscope "froze" the propeller, the strobe light being reflected along the line of sight of a TV camera by a polished stainless-steel sheet (see Figure 6-23). The camera, focussed through a hole in the sheet, televised the image of the blade in its rotational plane to a TV receiver outside the test cell, where tests could be safely observed by inspectors.

In another instance, a closed-circuit TV system was used as the result of complaints by sewing-machine inspectors that direct visual observation of the machines under stroboscopic light caused eye-strain. The TV camera, coupled with a 17X

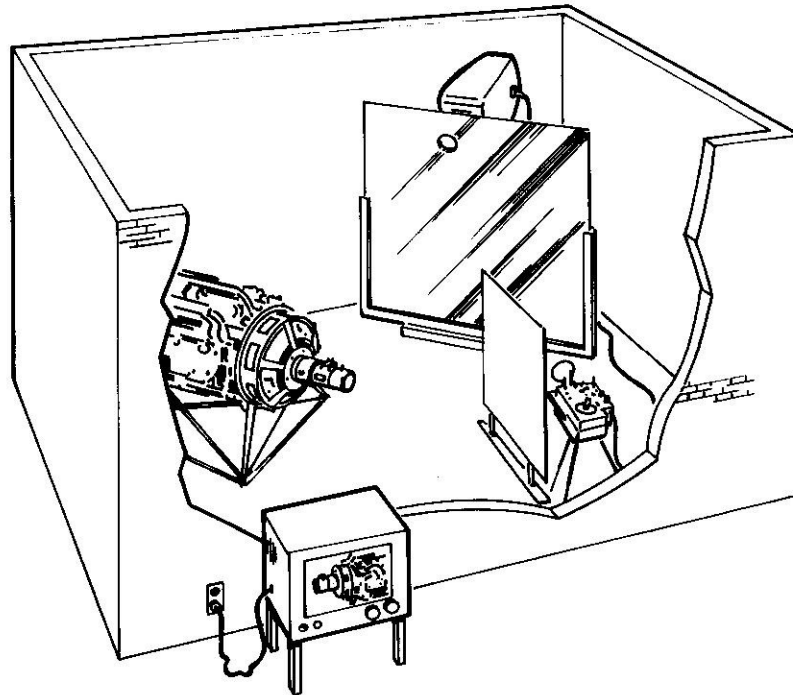

Figure 6-23. Propeller in test chamber can be studied at a safe distance by means of closed-circuit TV. In the above installation, the propeller is illuminated by stroboscopic light reflected along the line of sight of a TV camera.

magnifier, was aimed at the sewing machines while the inspectors watched the operation on a TV receiver in another room.

In addition to removing the observer from danger and annoyance, the TV-stroboscope combination also provides a very useful magnification of the object being observed.

24. Calibration of Camera Shutter Speed

If a camera with a focal-plane shutter is aimed at a fast-flashing Strobotac and the shutter is tripped, the film exposed should, when developed, yield a picture showing strips of progressively lighter and darker areas, corresponding to the successive flashes during the opening and closing of the shutter. If the flashing rate is 24,000 per minute (400 per second), four flashes should get through a shutter set at 1/100 second to produce four strips at different exposure levels. The spacing of the strips can be examined to study the action of the shutter.

For a given shutter speed, the accuracy of calibration increases with flashing rate. That is, the interval between flashes should be as short as possible, and certainly very short compared with the nominal shutter speed. For this reason, the 1538-A, with a flashing-rate capability of 150,000 per minute, is recommended for this application.

Where great accuracy is desired, one can use a photoelectric pickoff with a period-measuring counter. The camera shutter (not the focal-plane type) is placed between

a steady light and the pickoff. The opening and closing of the shutter thus switches the photocell on and off, and the time-on interval is indicated very precisely by the counter.

25. The Stroboscope as a Pulsed Light Source

Research studies on photosensitive materials and devices often require the use of a very brief pulse of light as a stimulator. The Strobotac's microsecond flash duration makes it well suited for this application.

The setup shown in Figure 6-24 was used to measure the lifetimes of minority carriers in silicon. The Strobotac, flashing 60 times per second, produced excess carriers in a silicon sample through which a constant current was passed. A 1-mm silicon filter was used to pass only those rays with enough energy to penetrate the bulk of the sample. The excess carriers are observed on an oscilloscope as a change in voltage across the sample.

$$\text{Mobility } \mu d = \frac{d\ell}{V_t} \quad (\text{cm}^2/\text{volt s})$$

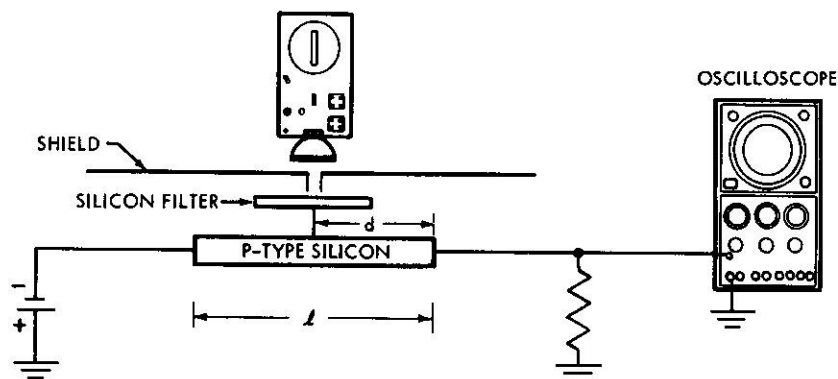

Figure 6-24. A setup for the measurement of drift mobility of silicon.

26. Ripple-Tank Photography with the Stroboscope

A popular high school physics demonstration involves the use of a shallow tank of water with a motor-agitator setup to generate waves for study. The addition of a stroboscope, synchronized with the wave-generating apparatus, permits photography of the wave phenomena and detailed examination of reflection, refraction, shape, spacing, etc.

In one such experiment, the Strobotac reflector was removed so that the flash tube acted as a stroboscopic point source. Then the Strobotac was placed on its side so that the orientation of the flash spark was vertical, with the flash tube extending over the edge of a table, two feet above the ripple tank and four feet from a white sheet placed at the foot of the tank. A camera, with lens set open at $f4.7$, was focused on the sheet. With the Strobotac synchronized to the motor shaft by a simple contact closure, the cyclic motion of the waves was frozen, and illumination could be provided by as many flashes as necessary to obtain a good exposure.



Figure 6-25. Shadowgraphs of bullet entering and leaving a soap bubble.

27. High-Speed Shadowgraphs with the Stroboscope

The dramatic photographs of Figure 6-25, showing a bullet entering and leaving a soap bubble, were made with a 1531 Strobotac in a fairly simple setup — so simple, in fact, that it did not include a camera! A microphone was used to detect the shock waves from the passing bullet. The pulse from the microphone was amplified and fed to the INPUT jack of the Strobotac. The Strobotac reflector was removed, and the range switch was set to the highest frequency range (to produce the shortest light flash). The Strobotac was placed a few yards in front of the bullet path, and a Polaroid 4 x 5 film back, loaded with Polaroid 3000 film, was mounted about 3-1/2 inches in back of the path. The room was completely darkened for the operation.

The soap bubble shown in Figure 6-25 was filled with Freon-12 to facilitate the study of sound and shock waves in the bubble.

28. Applications in Psychology and Physiology

The usefulness of the stroboscope as a diagnostic and research instrument is well recognized by psychologists and physiologists. The recording of brain waves during stroboscopic stimulation is an important diagnostic tool in the study of epilepsy. Also, the relation between flicker-fusion frequency (that frequency above which a flashing light appears continuous) and certain nervous disorders has been established. The frequency is quickly and easily determined by means of the stroboscope.

In the field of psychology, the stroboscope often serves as a tachistoscope — i.e., a source of brief flashes of known color, duration, and intensity. The occasional requirement for a flash duration longer than the few microseconds of the strobe flash is easily met by the addition of a tone-burst generator and oscillator. A burst of flashes thus produced is effectively the same as a single long-duration flash, as long as the flash rate during the burst is above the flicker-fusion frequency.

The stroboscope has also been used successfully to induce hallucinations, and one report has been received of its use to stimulate powers of extrasensory perception.

29. Roll-Label Inspection with the Strobotac

The advent of high-speed packaging machinery has focused attention on the inspection process as a possible bottleneck. The importance of speeding up inspection is especially urgent in the drug industry, where Federal laws require monitoring and counting of labels, and where high-speed roll-label equipment makes it doubly impractical to slow down the operation periodically for visual inspection.

The Strobotac has provided the answer for at least one drug manufacturer. The roll-label equipment is kept running at full speed, and the Strobotac is synchronized to the passage of labels by a photoelectric pickoff. As a bonus feature, the output signal from the Strobotac is fed to an electronic frequency counter, which keeps an accurate tally of labels passed.

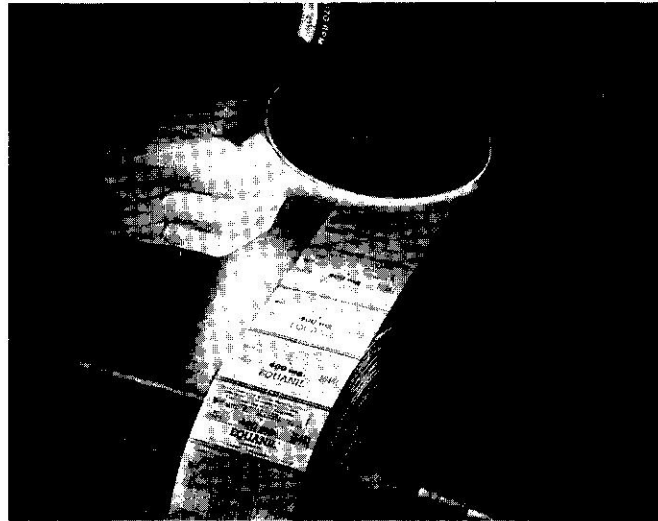

Figure 6-26. Stroboscopic monitoring of labels eliminates the necessity of slowing down or stopping high-speed machinery for spot checks.

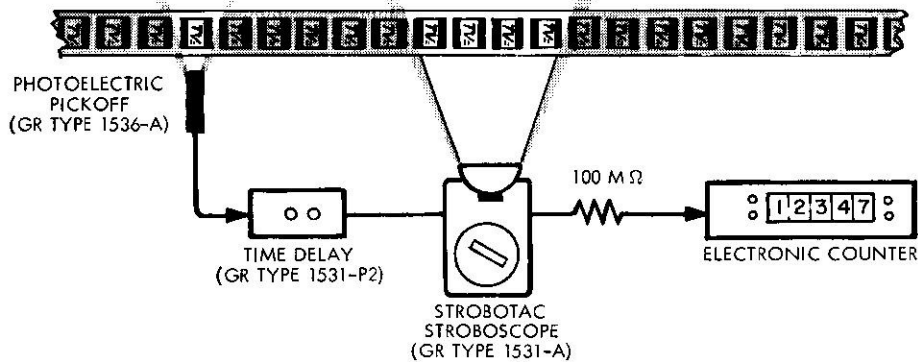

Figure 6-27. Complete setup for monitoring and counting labels.

The equipment setup is shown in Figure 6-27. The Flash Delay enables the inspector to control the position of the image being observed. One precaution: If too much delay is inserted, the photocell will skip frames, which will not seriously interfere with viewing but which will upset the label count.

30. The Strobotac as a Flutter Source

The Strobotac is well established as an excellent flicker source in flicker-fusion and similar tests (see application 28), but its usefulness as a flutter source is still relatively unknown. Flutter is the auditory equivalent of flicker, the flutter fusion frequency being that above which a clicking sound seems steady. The Strobotac, quite incidentally, is a source of high-speed clicks whose frequency is known to within one percent. Thus it is not surprising that some resourceful scientists have put these clicks to work in studies of the interdependence between flutter and flicker in human subjects.

31. The Strobotac in the Bottling Plant

A leading brewery uses the Strobotac to monitor operation of filling and capping machines that handle up to 1000 bottles per minute. Proper filling of each bottle before it is capped is indicated by the amount of head, or beer foam, that spills over the top of the bottle. With the Strobotac aimed at the filling operation, the operator was able to watch the foam level and make necessary adjustments to correct for over- or under-filling.

Obviously, in any bottling or canning operation, there are dozens of ways in which the stroboscope can be put to good use. As automatic packaging machines are developed with ever-higher operating speeds, the stroboscope becomes more and more essential. Fortunately, too, the higher the speed, the better the stroboscopic illusion.

32. Fuel-Spray Studies

One of the most important applications of the stroboscope is the analysis of fuel spray patterns. For example, high-speed diesel engines require, for efficient operation, not only accurate fuel distribution in each cylinder, but also a precise nozzle

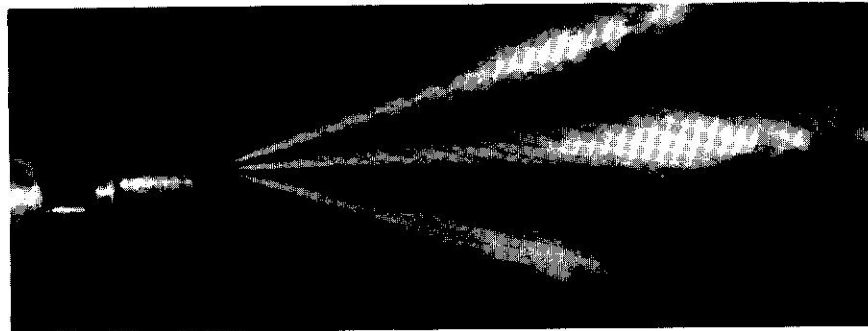

Figure 6-28. Stroboscopic examination of fuel spray patterns aids in design and inspection of nozzles.

spray pattern during its development in the combustion chamber. The Strobotac is widely used by manufacturers of diesel fuel-injection equipment to inspect nozzle sprays for comparison against master spray charts. The Strobotac is synchronized with the fuel pump by a photoelectric pickoff or mechanical contactor, and stroboscopic light is used to reveal the shape, penetration, and direction of each spray pattern. Thus are nozzles inspected for proper operation. Spray patterns can, of course, be analyzed in much greater detail by means of stroboscopic high-speed photographs.

33. Dynamic Models via Strobotac

Stroboscopic light can be used to produce some interesting dynamic models for the classroom. For instance, a simple model illustrating the operation of a four-cylinder engine can be constructed out of a piece of square pipe, with four tapped holes in each side. Screws placed in the holes represent pistons, and these are set at different heights so that as the pipe is rotated the "pistons" appear to reciprocate in the standard firing order. The pipe can be rotated by a lathe, with the stroboscope set near four times the spindle speed to produce a dramatic slow-motion illusion of piston operation.

34. Photoelastic Studies with the Strobotac

Impact-generated stress waves can be revealed in slow-motion for analysis by means of a simple setup including a Strobotac, a bell clapper, and a polariscope. The material to be analyzed is mounted in the polariscope with a bell clapper positioned to strike it repeatedly. By adjustment of the Strobotac frequency, the stress waves can be made to appear to travel fast or slowly, stop, or reverse. It is thus possible to study wave fringes and to study isoclinics. Photographic equipment can of course be introduced for more detailed analysis. It is an easy matter to vary the clapper position or striking energy and to observe the effects on the stress waves.

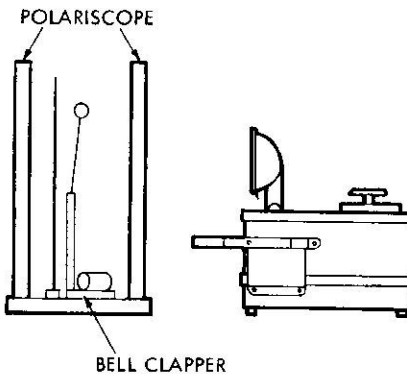

Figure 6-29. Photoelastic stress patterns can be studied in slow motion with relatively simple setup.

35. Precise Tachometry with the Strobotac

To improve the flashing-rate accuracy of the Strobotac by several orders of magnitude, all one has to do is to use a good quartz-crystal oscillator as an external triggering source. The more accurate the standard frequency used to drive the Strobotac, the more accurate the flashing rate. A frequency synthesizer, such as one of GenRad's 1060 series, provides not only high accuracy but the convenience of pushbutton frequency selection, remote programming, etc.

In selecting a frequency source, one should keep in mind the sensitivity and frequency limitations of the Strobotac. If the standard frequency is above 400 cycles per second, a frequency divider must be used. It must also be remembered that the accuracy transfer is valid only at the driving frequency and its harmonics.

An interesting method of frequency calibration involves the use of a broadcast audio-frequency standard signal (such as the 400-Hz tone on WWV). The signal is fed from a receiver to the vertical plates of an oscilloscope, and an audio oscillator is connected to the horizontal plates and, through an amplifier, to the stroboscope. The audio-oscillator frequency is then adjusted for a 1-to-1 Lissajous pattern on the oscilloscope, or, for frequencies harmonically related to the reference, for the appropriate multiple Lissajous pattern.

Among the many signal sources made by GenRad, the GR 1310 Oscillator is especially attractive as a driver for the Strobotac, since it can be phase-locked to an external frequency standard and has enough output to trigger the Strobotac directly.

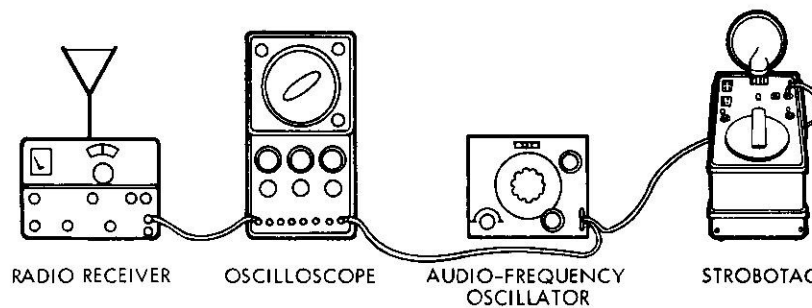

Figure 6-30. Flashing rate can be calibrated in terms of standard frequencies generated locally or received off the air.

36. A Railroad Application

Close-up photographs of the wheels of a freight train moving at 60 miles per hour were easily taken with the aid of the Strobotac. A flip-flop triggering circuit was armed by the passage of a wheel to fire the Strobotac once only, as the next wheel passed. A single Polaroid camera, with shutter open, took the picture, after which the shutter was closed, the film processed, and the flip-flop armed for another shot. Purpose was to check the position of the wheel relative to the action of a wheel detector, which in turn is used in "hot-box" detection.

37. . . Any Many, Many Others

The Strobotac is used to detect wobble (of as little as 5 mils) of a circular saw blade used to cut germanium wafers for transistors.

The Strobotac has been used to create special animated stage effects at a Las Vegas nightclub.

A common use of the Strobotac is to "stop" the high-speed rotating heads of magnetic tape recorders, for speed measurement and motion analysis.

In a video storage system, the Strobotac is used to produce the brief illumination necessary to produce a single TV frame of a scene, which can then be scanned repeatedly for a flickerless TV display.

In a vibration test setup to measure the elasticity of leather, a Strobotac is used to measure the vibration frequency and to observe the leather sample under vibration for displacement measurement.

A Strobotac has been used to measure speed of rotating anodes in magnetron tubes immersed in oil baths.

Two stroboscopes flashing through different-colored filters, with one delayed with respect to the other by a time-delay generator, have been used to measure the variation in human optical response time to flashes of different wavelengths.

A leading jet-engine manufacturer uses the Strobotac, with optical magnifiers, to study the vibratory modes of small aircraft gas turbine blades.

Helicopter propeller blade whip and other characteristics are studied in the aeronautical laboratory with the aid of the stroboscope.

Two of the simplest objects for stroboscopic demonstrations are a top and a spinning coin.

If a sight glass containing a small, pivoted turbine is installed in and normal to a pipe section, a stroboscope can be used to measure the speed of the turbine and therefore the velocity of fluid in the pipe. With appropriate transducers to convert quantities into motion, the stroboscope has been used to measure temperature, torque, horsepower, gas volume flow, burning velocity, sound frequency, and many other parameters.

The stroboscope has been used to photograph the extremely fast motion (up to 5000 feet per second) of glass fracture.

Several medical researchers regularly use the Strobotac to observe the operation of artificial hearts.

A zoology professor uses the Strobotac and a microscope to determine the frequencies of cilia and flagella.

The Strobotac is used by audiologists to observe the action of vocal chords.

In steel mills, the Strobotac is used to inspect strip steel moving at speeds well over 1000 feet per minute.

A speed-reading clinic uses the Strobotac to improve recognition-time capabilities of students.

Nomographs for use in measuring speeds beyond the flashing rate of the Strobotac

The nomographs on the following two pages can be used to determine quickly the fundamental speed of an object from two successive submultiple images. Figure A-1 is for use with the 1531 Strobotac, Figure A-2 for the 1538-A Strobotac.

To use the nomograph, find the point on the X scale corresponding to the highest flashing rate at which a true stopped-motion image occurs. Then find the point on the Y scale where the *next lower* true stopped image occurs. Hold a straightedge so that it intersects the X and Y scales at the points plotted. The straightedge should intersect the n scale at an integer. Multiply the X scale value by this integer to determine the fundamental speed.

Examples:

In Figure A-1, suppose that the first true stopped-motion image is obtained at 20,000 rpm, the next lower one at 15,000 rpm. A line drawn through 20 on the X scale and 15 on the Y scale intersects the n scale at 3. Therefore the fundamental speed is $3 \times 20,000$ rpm, or 60,000 rpm.

In Figure A-2, suppose that the first time stopped-motion image is obtained at 150,000 rpm, the next lower one at 120,000 rpm. A line drawn through 150 on the X scale and 120 on the Y scale intersects the n scale at 4. Therefore the fundamental speed is $4 \times 150,000$, or 600,000 rpm.

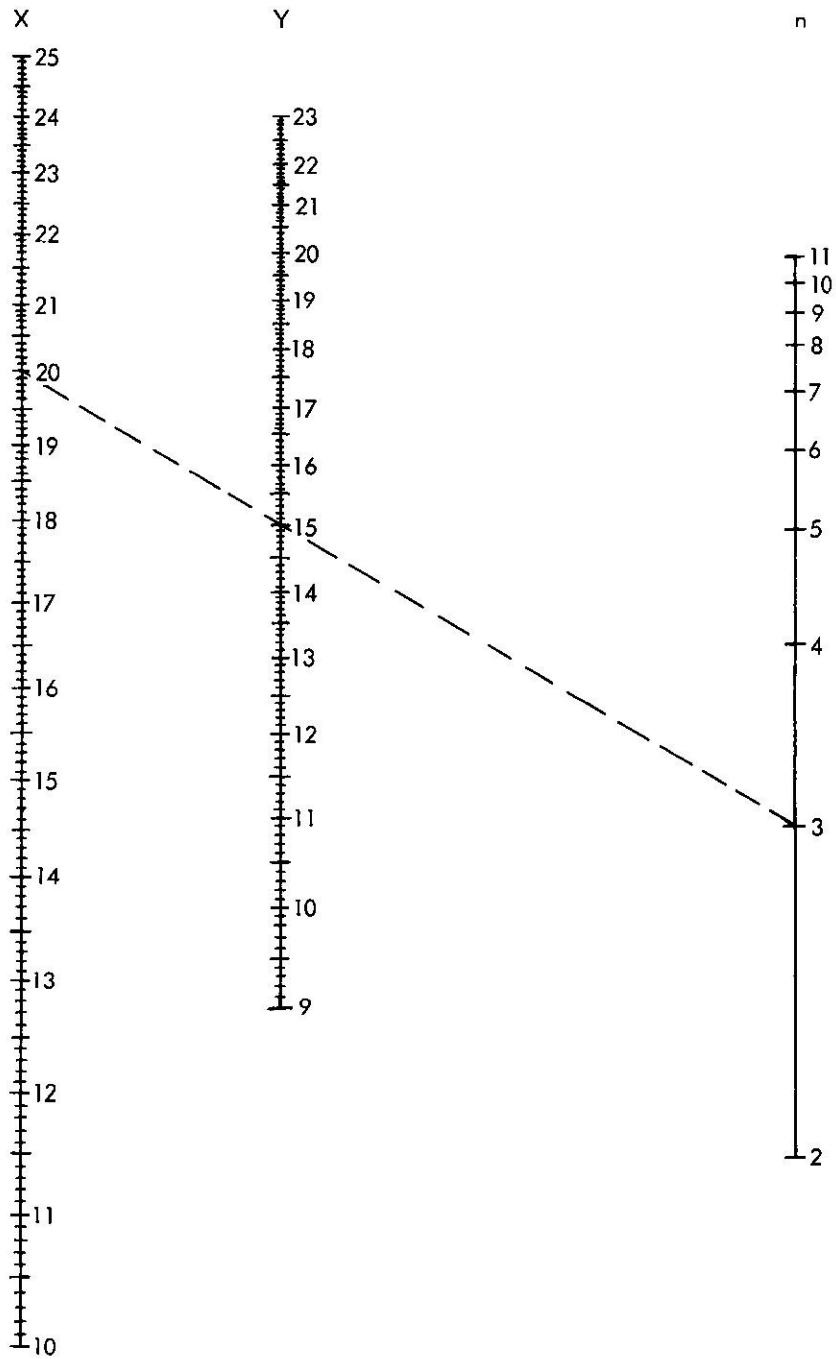

Figure A-1. Nomograph for use with GR 1531 Strobotac.

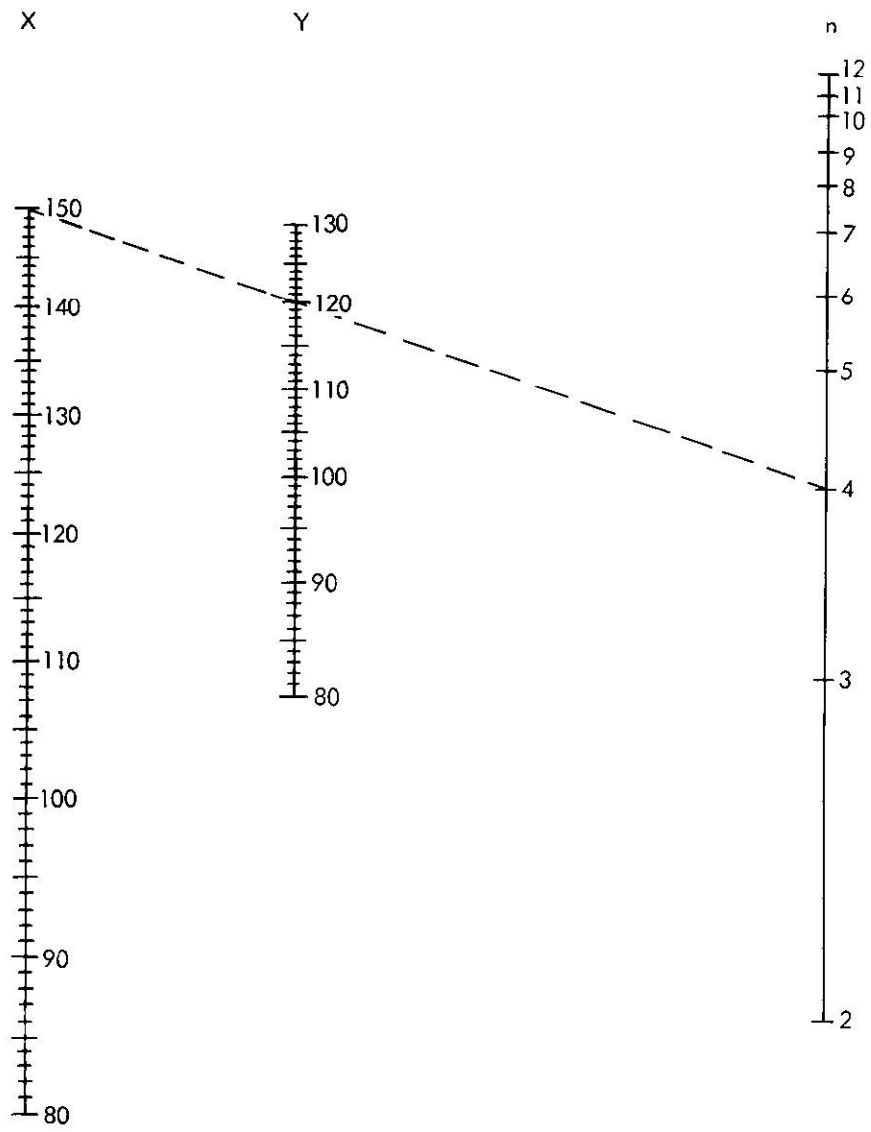

Figure A-2. Nomograph for use with GR 1538-A Strobotac.

Bibliography

GENERAL

- Edgerton, H.E., *Electronic Flash, Strobe*, McGraw-Hill Book Co., New York, 1970.
- Kivenson, G., *Industrial Stroboscopy*, Hayden Book Company, Inc., New York, 1965.
- Littell, R., "Stopping Time," *Scientific American*, February 1940.
- Rutkowski, J., *Stroboscopes for Industry and Research*, Pergamon Press, New York, 1966.
- Van Veen, F., "Industry's Watchdog – The Stroboscope," *Safety Maintenance*, January 1961.

PHOTOGRAPHIC APPLICATIONS

- Beattie, K., "First Action Photographs of Cavitation," *Baldwin Southwark*, September 1940.
- Clayton, J., "Single-Flash Photography with the Strobotac and the Strobolux," *General Radio Experimenter*, November 1940.
- Crow, D., "Photographing Gasoline Drops," *Industrial Photography*, October 1965.
- Edgerton, H., "Stroboscopic Moving Pictures," *Electrical Engineering*, May 1931.
- Eldridge, D., Skinner, E., and Tsepas, J., "Strobe Photography with the General Radio 1531-A Strobotac," *American Journal of Physics*, December 1962.
- Newman, Charles B., "High Speed the Melpar Way," *Industrial Photography*, April 1962.
- Odenburger, R., "Human Trajectories," *Journal of Applied Physics*, July, 1942.
- Wasil, B., Merchant, D., and Del Veccio, J., "Photogrammetric Measurements of Dynamic Displacements," *Experimental Mechanics*, October 1965.
- Wyckoff, C. and Edgerton, H., "Xenon Electronic Flash Sensitometer," *Journal of the Society of Motion Picture and Television Engineers*, August 1957.
- Handbook of High-Speed Photography*, General Radio Company, West Concord, Mass., 1966.

TEXTILE APPLICATIONS

- Burke, C., "New Stroboscope—A Practical Mill Device," *Textile Age*, March, 1938.
- Cantrell, F., "Keep Your Looms in Top Condition," *Textile World*, June 1951.
- Chouinard, A., "A Stroboscopic Study of Endless Check Straps," *Modern Textiles*, December 1954.
- Ellington, Jesse W., "Textile Stroboscopy," *Textile Industries*, January and February 1966.
- McConnell, D., "Stroboscope Engineering Gives Answers," *Textile World*, March 1946.
- Mitchem, R., "Intelligent Use of Strobotac," *Textile World*, October 1942.
- Saylor, W., "Stroboscopic Measurements at the Loom," *Textile Age*, June 1952.
- Schremp, E., "Uniform Loom Setting," *Textile World*, June 1951.
- Zeluff, V., "Electrons Guide the Loom," *Scientific American*, November 1946.

MISCELLANEOUS

- Adams, K., "Measuring 0.003 Horsepower with the Strobotac," *General Radio Experimenter*, April 1945.
- Anderson, R., "Dynamic Balancing with Portable Equipment," *Instrument Note IN107*, General Radio Company, West Concord, Mass. 01742
- Arguimbau, L., "A Stroboscopic Frequency Meter," *General Radio Experimenter*, November 1930.
- Becker, H., "Simplified Equipment for Photoelastic Studies of Propagating Stress Waves," *Proceedings of the Society for Experimental Stress Analysis*, Vol XVIII No. 2, 1961.
- Cox, W., "Vibration Testing with Automatic Stroboscopic Instrumentation," Instrument Society of America 17th Annual Conference and Exhibit, 1962; *Preprint 20.2.62*.
- Dowell, M., "A Study of Air Movement Through Axial-Flow Free-Air Propellers," *GE Review*, May 1939.
- Eskeland, R. and Oakley, R., "Stroboscopic Label Inspection," *Modern Packaging*, August 1965.
- Fitzmorris, M., Lahanas, C., and Thurston, W., "New Eyes For Modern Industry — The Type 1531-A Strobotac®," *General Radio Experimenter*, September 1960.
- Glew, N., "Closed-Circuit Television and the Stroboscope," *Industrial Electronics*, November 1963.
- Goodman, L. and Bowie, G., "A Stroboscopic Light Source for a Tuckerman Auto-collimator," *Experimental Mechanics*, February 1961.
- Holtje, M., "Flash! A New Strobotac," *General Radio Experimenter*, April 1966.
- Holtje, M., "Introducing the Stroboslave," *General Radio Experimenter*, April 1966.
- Kivenson, G., "Strobes for Vibration Measurement," *Machine Design*, September 2, 1965.
- Miller, C.E., "Using Stroboscopy for Stop-Action Study of High-Speed Events," *Machine Design*, April/May 1969.
- Mills, E. and King, W., "Portable Set Aids Balancing," *Allis-Chalmers Electrical Review*, 1st Quarter 1948.
- Moslander, K., "Stopping Motion for Design Data," *Machine Design*, June 1941.
- Schweitzer, P., "Fuel-Injection Phenomena Explored by Stroboscopic Studies," *Diesel Power and Diesel Transportation*, February 1944.
- Sharp, R., "Cavitation of Hydraulic-Turbine Runners," *ASME Transactions*, October 1940.
- Shipley, T., "Auditory Flutter-Driving of Visual Flicker," *Science*, September 18, 1964.
- Stengel, R., "Photoelectrically Triggered Strobe Flash Monitors Rotary Printing," *Design News*, May 29, 1963.
- Sundt, E., "Touchless Tachometry," *Electromechanical Design*, May 1964.
- Tsunoda, K., "Stroboscope Tells Belt Tension," *Power Transmission Design*, November 1963.
- Vogel, S. and Feder, N., "Visualization of Low-Speed Flow Using Suspended Plastic Particles," *Nature*, January 8, 1966.
- Wolf, W., "Study of the Vibrating Reed in the Production of Small Droplets and Solid Particles of Uniform Size," *Review of Scientific Instruments*, October 1961.

Glossary of Terms used in Stroboscopy

The following definitions apply in the context of this handbook.

Beam Angle	The angle, in degrees, over which the intensity of stroboscopic light is at least one half its peak value.
Beam Candle	The unit of luminous intensity measured at the center of the beam from a reflector.
Candle	The unit of luminous intensity of a point source; 1/60 of the intensity of one square centimeter of a black-body radiator at the temperature of the solidification of platinum.
Contactator	A set of electrical contacts used to open and close a stroboscope's triggering circuit and thus to synchronize the flashes with the motion of some object.
Flash Delay	A stroboscope accessory, which introduces an adjustable time delay between the action of a photoelectric pickoff or contactator and the stroboscope's flash, in order to control the phase of the flash with respect to the motion being observed.
Flash Duration	The time interval of a stroboscope's flash, measured between the points of one-third peak intensity.
Flicker	The optical sensation of intermittent rather than continuous light.
Fundamental	As applied to flashing rate, that rate at which one flash occurs for each cycle of the motion being observed.
Harmonic	A frequency that is an integral multiple of another. The second harmonic of 6000 rpm is 12,000 rpm.
Holdover	In a strobotron or triggering device, a state of continuous conduction caused by failure of the tube or device to return to a nonconducting state after firing.
Lumen	The unit of luminous flux, equal to the flux through a unit solid angle (steradian) from a uniform point source of one candle, or to the flux on a unit surface all points of which are at unit distance from a uniform point source of one candle.
Lux	The unit of luminous density, equal to 1 lumen per square meter.
Multiple-Image Photograph	A photograph showing successive stages of an action, made by exposing a single film frame to successive flashes of light.

Phase	The relationship of the instantaneous position of a cyclically moving object to the position of another moving object, to a stroboscope's flash, or to any reference point.
Photoelectric Pickoff	A stroboscope accessory, consisting of a photocell, mounting, and connecting linkage, designed to detect light reflected or directed by a moving object and to supply synchronizing triggering pulses to a stroboscope.
Strobolume [®]	A trade name used to describe a high-intensity electronic stroboscope manufactured by GenRad.
Stroboscope	An instrument that produces the optical illusion of slowed or stopped motion by permitting periodic observation at a rate at or near synchronism with the device being observed.
Stroboslave [®]	A trade name used to describe a simplified, compact electronic stroboscope manufactured by GenRad.
Strobotac [®]	A trade name used to describe certain electronic stroboscopes manufactured by GenRad.
Strobotron	A gas-filled tube used as the light source in stroboscopes.
Subharmonic	A flashing rate that is an integral submultiple ($1/2$, $1/3$, $1/4$. . . etc) of the speed of the device being observed.
Surface Speed Wheel	A disk whose circumference is such that, when the disk is caused to rotate by contact with a moving object (such as a belt), the surface speed of the object is simply related to the rotating rate of the disk. This simple relationship is used as the basis for stroboscopic measurement of surface speed.

appendix D
Catalog Section

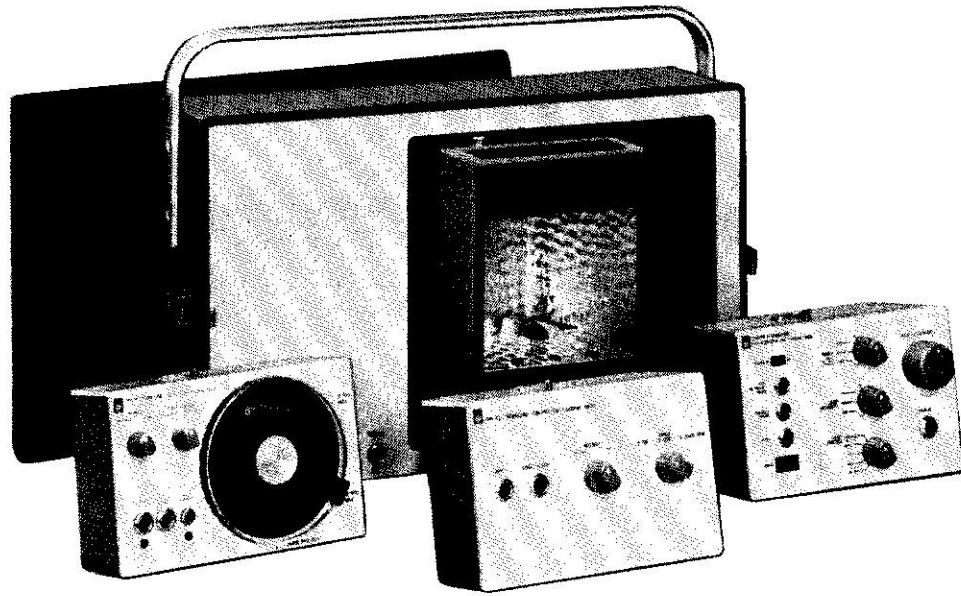

Strobolume® electronic stroboscope

1540

- flash rates to 25,000 per minute
- brilliant white light
- wide-beam flood area for photography and TV

Stopped motion With the aid of a stroboscope you can examine the motion of machines, objects exploding or in flight, fluid spray patterns, and many other events as though they were motionless. With a calibrated stroboscope, you can measure the rate of repeating motion to 1% accuracy up to $\frac{1}{4}$ million rpm.

With the bright-light 1540 Strobolume® electronic stroboscope, you can perform all these tasks, and more, under difficult lighting conditions and even make color stopped-motion photographs or make videotapes. The 1540 is the first stroboscope to generate so much light and also provide the versatility for general-purpose uses. Three control units are available; with the right one for the job, the 1540 can be flashed continuously or synchronized with the motion or camera for single flashes or bursts. Thus, you can "hold" cyclic motion in one chosen position, freeze a once-only event on film or tape, or expose a motion to multiple-flash analysis.

Bright flashes Every one is a pulse of white light lasting less than 15 microseconds and illuminating a 7-by-13-foot area, 10 feet away, with brilliance enough for still or movie photography or TV recording.

The flash can be triggered from a photoelectric pickoff, the opening or closing of a switch contact or camera shutter, or an electrical pulse or sine-wave signal. The flash can occur at the instant of the triggering event or be delayed by any desired time from 100 microseconds to 1 second to catch a subsequent event.

Versatile construction The working part of the Strobolume stroboscope is the lamp head to which one of the three control units attaches, either directly or by extension cables for remote operation. The combination is small and easy to hold or mount on a tripod. A twelve-foot cable brings dc power from the larger power supply/carrying case.

To use, aim the lamp at the object to be studied (from a distance determined by the area to be illuminated and the amount of light needed). Connect the camera (any ordinary type with "X" flash synchronization) and photoelectric pickoff to the control unit and set the controls to "stop" the motion at the right point. Set the strobe for single flash, operate the shutter, and you have a picture.

SPECIFICATIONS

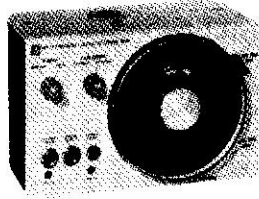

1540-P1 Strobolume® Oscillator

For speed measurements and general use Provides internally generated flashing rates, accurate to 1%, for general use and is particularly well-suited for speed measurements from 110 to 25,000 rpm.

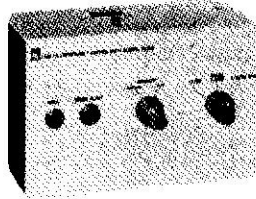

1540-P3 Strobolume® Control Unit

For use with external equipment Provides flashes only in response to external signals.

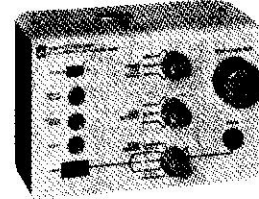

1540-P4 Oscillator/Delay Unit

For motion analysis and photography Provides internally-generated flashing rates and is the only unit that provides gated bursts of flashes as well as variable delay between receipt of a trigger and each flash. Well suited to photography; the flash can be synchronized with both motion and camera.

Flash Rate (flashes per minute): 0 to 25,000 external; single flash by means of panel pushbutton; 110 to 25,000 internal by means of calibrated control in 3 overlapping decade ranges with 1%-of-reading accuracy.	0 to 25,000 external; single-flash by means of panel pushbutton.	0 to 25,000 external; single-flash by means of panel pushbutton; ≈ 30 to 25,000 internal by means of uncalibrated control in 3 overlapping ranges. MULTIFLASH MODE permits flash bursts as long as panel pushbutton is depressed or contact closure exists at Camera jack, flash rate is set by panel controls.
Trigger: INPUT: From 1537 Photoelectric Pickoff; contact closure; ≥ +1-V pulse, or ≥ 3.5 V rms sinewave at flash rate of 300, decreasing to 0.35 V at flash rates of 6000 to 25,000. OUTPUT: > +6-V pulse behind 600 Ω.	INPUT: From 1537 Photoelectric Pickoff; contact closure; or ≥ +1-V pulse. OUTPUT: None.	INPUT: From 1536 (light-to-dark or dark-to-light transitions) or 1537 Photoelectric Pickoff; contact closure or opening; ≥ +1-V pulse; ≥ 0.35 V rms sinewave. OUTPUT: > +10-V pulse behind 10 kΩ.
Camera: single flash from contact closure	single flash from contact closure	yes, see below
Delay: none	none	yes, see below

1540-P4 Characteristics: CAMERA INPUT: Permits "X" contact closure of camera to cause flash at instant of contact closure, delayed flash synchronized to subject by external trigger signal, or multiframe "burst." DELAY: Time from external trigger to flash is continuously adjustable from ≈ 100 μs to 1 s, uncalibrated control, 3 overlapping decade ranges. RATE of multiframe: 30 to 25,000 per min, continuously adjustable, 3 overlapping ranges.

Light Output: Measured with silicon photo detector 1 meter from lamp at maximum beam width of ≈ 40x65° (7.5x13 ft at a distance of 10 ft); can be narrowed to ≈ 17x65° (3x13 ft), intensity increases as beam narrows; beam width measured at ½-intensity points:

Intensity Range	Low	Medium	High
FLASH RATE, per minute	690 max	4170 max	25,000 max
FLASH DURATION*	15 μs	12 μs	10 μs
ENERGY*, watt-seconds	10	1.8	0.25
BEAM INTENSITY*, candela	16x16*	4x10*	0.5x10*

* For low flash rates. Energy is electrical input to lamp.

Auxiliary input is provided for connecting a booster capacitor to increase single-flash intensity.

Remote Programming: Can be controlled by external signals, applied to rear of lamp assembly, in place of any control unit. INTENSITY: Range selection by switch closures to ground; required ratings 28 V, 60 mA. FLASH: Triggered by pulse of ≥ +0.75 V, which must not occur while intensity range is being changed.

Environment: VIBRATION: 0.03 in. from 10 to 30 Hz. BENCH HANDLING: 4 in. or 45° (MIL STD-810-VI). SHOCK: 30 g, 11 ms.

Supplied: Power cord, 12-ft flat cable for connection of lamp head to mainframe, pouch containing adjustable neck strap for combination lamp head and control unit, phone plug for trigger input/output jacks, 6-ft cable for remote connection between lamp head and control unit.

Available: 1536 and 1537 Photoelectric Pickoffs; extension cables for greater separation between mainframe, lamp head, and control unit.

Power: 100 to 125 and 195 to 250 V, 50 to 60 Hz, 250 W max.
Mechanical: Mainframe housed in portable cabinet and contains power supply, lamp head in associated storage compartment, and storage space for one control unit and cables.
DIMENSIONS (wxhxd): Case (closed), 19x8x13.75 in. (483x203x349 mm); lamp head with control unit attached, 9.25x5.5x8.5 in. (335x140x216 mm). **WEIGHT** (including one control unit): 32 lb (15 kg) net, 39 lb (18 kg) shipping.

Description	Catalog Number
1540 Strobolume® electronic stroboscope mainframe, includes 1540-P2 lamp head and power supply.	1540-9600
Select at least one of the following control units, unless the 1540 is to be remotely programmed:	
1540-P1 Strobolume® oscillator	1540-9601
1540-P3 Strobolume® control unit	1540-9603
1540-P4 Oscillator/Delay Unit	1540-9604
1540-P2 Strobolume® lamp, additional assembly	1540-9602
1540-P5 Strobotron Flash Lamp, replacement	1540-9605

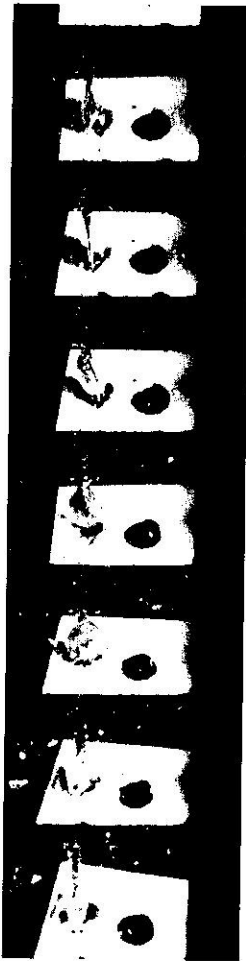

The 1540 is a valuable, economical, high-speed photographic tool. This sequence follows the action of a 2000-rpm wood bit going through a piece of particle board.

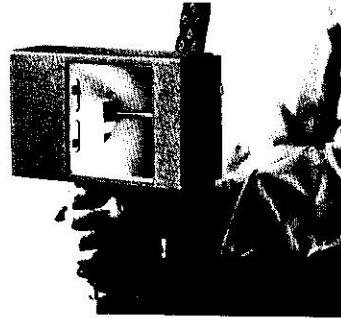

The lamp-head assembly can also be hand-held separately using the pistol-grip handle supplied.

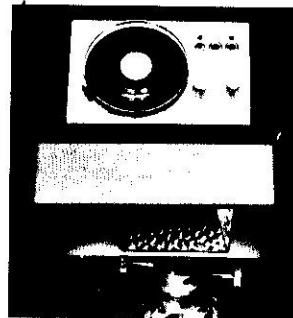

The control unit and lamp-head assembly can be attached together and mounted on a tripod for convenience or, with the neck strap supplied, can be made as portable as your need dictates.



Its brightness and versatility make this strobe a natural for TV applications such as video recordings of rapidly-moving parts in mechanical devices.

Strobotac[®] electronic stroboscopes

1531-AB and 1538-A

- speed measurements to 1 million rpm; 1% accuracy
- bright white light for high-speed photography, for observations in any normal ambient light
- simple to use, easy to handle

Compact and accurate These stroboscopes are small portable flashing-light sources used to measure the speed of fast-moving devices or to produce the optical effect of stopping or slowing high-speed motion for observation. A built-in system uses the power-line frequency for quick and easy checks and adjustment of the flash-rate calibration. Each flash-lamp/reflector assembly is hinged at the panel and the reflector swivels 360 degrees, for complete flexibility. The cases have standard sockets (0.25x20 threads/inch) for tripod mounting. The instruments are all approved by CSA Testing Laboratories.

Versatile synchronization A variety of trigger inputs can be used for flash synchronization. Contact closures, pulses, or sinewave signals will trigger the flash and an output trigger is provided so the stroboscope, in turn, can trigger another device. A 1536 Photoelectric Pickoff can be used with a 1531-P2 Flash Delay to provide an adjust-

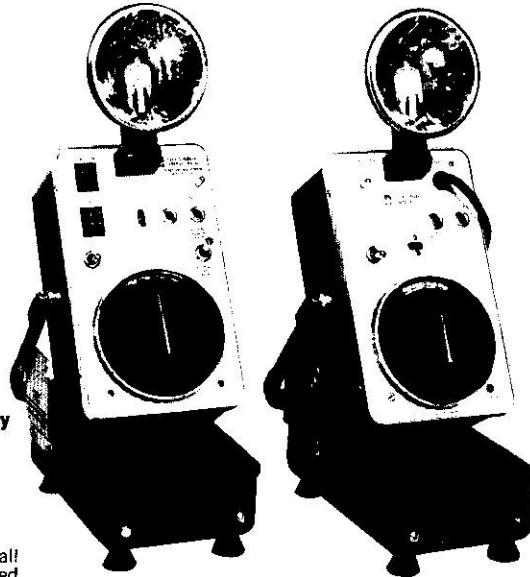

able delay between the time a selected point on a moving object passes the pickoff and the time the strobe flashes. Single-flash photographs of high-speed motion are a snap with any still camera when the 1531-P2 is used.

The difference The 1531 is more economical to buy. On the other hand, the 1538 gives you six times the maximum flash rate of the former and also works with accessories that increase the single-flash light output (for example) by a factor of about 6, provide the convenience of an extension lamp, and enable portable operation with a rechargeable battery.

— Note: These stroboscopes are manufactured also in Europe.

SPECIFICATIONS

1531-AB: Accurately calibrated flash rates to 25,000 per minute.



1538-A: Accurately calibrated flash rates to 150,000 per minute, accessories for brighter light, extension lamp, and battery operation.



Flash Rate in flashes per minute:

110 to 25,000 in 3 ranges; speeds up to 250,000 rpm can be measured. ACCURACY: $\pm 1\%$ of reading after calibration on one range against 50-to-60 Hz line frequency.

110 to 150,000 in 4 ranges; speeds to 1,000,000 rpm can be measured. ACCURACY: $\pm 1\%$ of reading after calibration on 670-to-1170 rpm range against 50-to-60 Hz line frequency.

External Trigger, input and output connections are phone jacks:

INPUT: Contact opening, pulse $\geq +6$ V pk-pk, or sinewave ≥ 2 V rms for $f > 5$ Hz. OUTPUT: Negative pulse ≥ 500 to 1000 V.

INPUT: Contact closure, pulse $\geq +1$ V pk-pk, or sinewave ≥ 0.35 V rms for $f > 100$ Hz (3.5 V at 10 Hz). OUTPUT: $\geq +6$ V behind 400 Ω .

Light Output: Beam width 10° at $1/2$ -intensity points for both units:

	Duration*	Energy** watt-seconds	Beam Intensity† candela
at 690 fpm	3 μ s	0.5	11x10 ⁶
at 4170 fpm	1.2 μ s	0.09	3.5x10 ⁶
at 25,000 fpm	0.8 μ s	0.014	0.6x10 ⁶
at 150,000 fpm			

	Duration*	Energy** watt-seconds	Beam Intensity† candela
	3 μ s	0.5	15x10 ⁶
	1.2 μ s	0.09	5x10 ⁶
	0.8 μ s	0.014	1x10 ⁶
	0.5 μ s	0.0023	0.16x10 ⁶

* Measured at $1/2$ peak intensity; for 1538 with -P4, duration is 8 μ s.

† Measured with silicon photo detector 1 meter from lamp; single-flash beam intensity for 1531 is $\approx 18x10^6$ and for 1538 with -P4 it is $\approx 44x10^6$ candela.

** Electrical input to lamp.

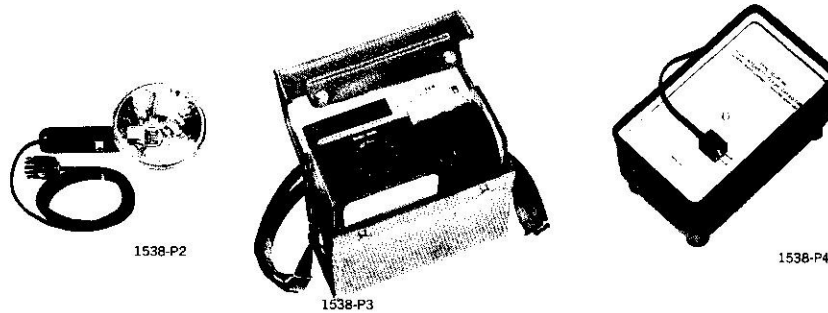

Supplied: Adjustable neck strap, phone plug for input and output jacks, power cord.

Available: 1536 and 1537 Photoelectric Pickoffs, 1531-P2 Flash Delay.

Power: 100 to 125 or 200 to 250 V, 50 to 400 Hz, 25 W max for 1531, 15 W max for 1538; 1538 can also be powered from 20 to 30 V dc, 12 W max, such as from **1538-P3** Battery and Charger that provides up to 6 h of continuous, completely portable operation and recharges in 14 h.

Mechanical: Flip-Tilt Case. DIMENSIONS (wxhxd): 10.63x6.63x13 in. (270x168x156 mm); 1538 with -P4 is 3 in. (76 mm) higher. WEIGHT: 7.5 lb (3.5 kg) net, 10 lb (4.6 kg) shipping; 1538-P4 is 5 lb (2.3 kg) net, 7 lb (3.2 kg) shipping.

Description	Catalog Number
1531-AB Strobotac® electronic stroboscope 115-V Model ♦ 230-V Model	1531-9430 1531-9440
1538-A Strobotac® electronic stroboscope 115-V Model 230-V Model	1538-9701 1538-9702
Accessories for 1538-A Only	
1538-P2 Extension Lamp, cannot be used when 1538-P4 is used	1538-9602
1538-P3 Battery and Charger	1538-9603
1538-P4 High Intensity-Flash Capacitor, increases light output by approx 6 times	1538-9604
1531-P2 Flash Delay, for 1531 or 1538 115-V Model 230-V Model	1531-9602 1531-9605
1538-P1 Replacement Strobotron Flash Lamp, for 1531 or 1538 ♦♦	1538-9601
Patch Cord , connects one strobe to another or to 1531-P2 Flash Delay	1560-9676
U.S. Patent Numbers 2,977,508 and 3,339,108.	

Strobotac® electronic stroboscopes 1542-B, 1543 and 1544

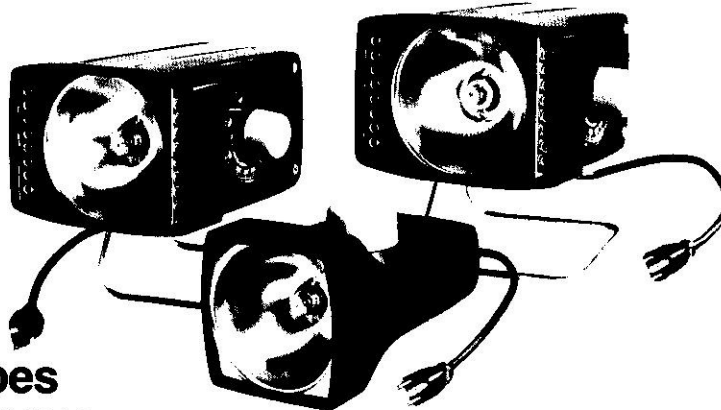

Feature-packed, low-cost capability

- Up to 3800 bright-white flashes per minute — to observe motion as fast as 40,000 rpm
- Wide-range continuous flash-rate control
- Low-cost, excellent OEM strobes, special versions available
- Simple pushbutton operation
- Compact, light-weight, rugged

Tailored for convenient operation These strobes were designed specifically for inspection applications and feature simple pushbutton control with a single knob to control the flash rate — no range switching is ever necessary. These strobes include unique electronically compensated output for visually constant image brightness (as the flash rate decreases, the light intensity increases). All are housed in a tough plastic case that is designed for comfortable hand-held operation and includes a threaded hole for tripod mounting.

♦ National Stock Number 6680-00-880-1844
♦♦ National Stock Number 5960-00-781-1466

All components are industrial grade and the engineering is completely thorough, including exacting environmental testing to ensure reliable operation under extreme conditions.

The 1542-B — simple, economical The 1542-B is as easy to operate as an extension lamp but is considerably more useful. Plug in the attached power cord, push the On-Off button, point the light at the action, and turn one knob until the visual image of the action slows to the desired rate or stops. That's the sum total of the operation — plug, push, point, and turn!

The 1543 — triggerable In addition to the features of the 1542-B, the 1543 includes provision for external triggering and line sync. The capability of the flash to be triggered by an external contact closure is especially valuable when the motion varies or is erratic and when perfect synchronization is desired, such as with a camera for high-speed photography. A special trigger circuit automatically counts down when the input rate exceeds the normal flash rate (giving you a flash for perhaps every second or third trigger) thereby providing for a sharp, flicker-free view. The line-sync mode allows the internal oscillator to be synchronized to a submultiple of the line frequency (3600, 1800, 1200, 900 fpm, etc). This feature is valuable for studies of line-frequency-related motion, as an accurate time base for graphic studies of acceleration and velocity, or for measurements of motor slip speed in accordance with IEEE 112A and 114.

The 1544 — delay triggerable The 1544 provides all the features of the 1543. In addition, it can be externally triggered by positive pulses and from a photoelectric pick-off, as well as contact closures, and its flash can be delayed from the moment of an external trigger by any dura-

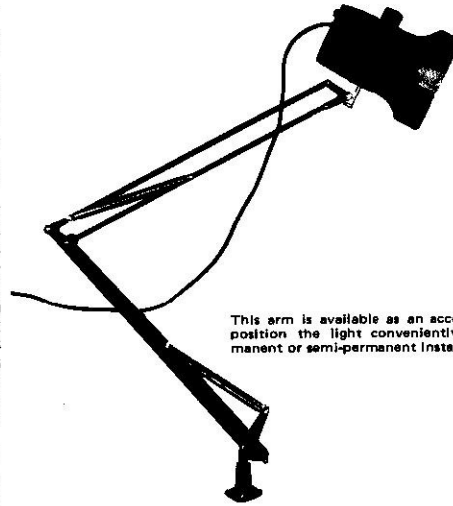



This arm is available as an accessory to position the light conveniently in permanent or semi-permanent installations.

tion from approximately 16 to 330 milliseconds. This delay feature is quite useful to vary the position of the stopped image in order to observe different phases of cyclic motion.

— Note: 220-volt versions of these strobes are manufactured in Europe.

SPECIFICATIONS

	1542-B: Simple, most economical NEW bright light 	1543: Line sync and contact-closure trigger 	1544: Line sync, contact-closure, photo-electric, and delayed triggers 												
	For education and general-purpose inspection and design applications	For photographic, educational (especially the physics lab), and general-purpose inspection and design applications	For printing, textile, photographic, educational (mechanical engineering), mechanical design, and general-purpose inspection applications												
Flash Rate in flashes per minute (fpm):	180 to 3800, continuously adjustable over a single range by a 5-turn uncalibrated control.	180 to 3800, continuously adjustable over a single range by a 10-turn control marked in approximate flash rate. Line-sync mode provides $\approx 0.1\%$ accuracy (60-Hz line in U.S.A.) by synchronizing to integer submultiples of line frequency.													
External Trigger:	None	Contact closure (isolated from ground) applied to phone jack.	Contact closure, positive signal > 2 V peak, or GR 1536 Photoelectric Pickoff.												
Trigger Delay:	None	None	≈ 16 to 330 ms from application of external trigger; set by flash-rate control.												
Light Output , Beam width 10° at $\frac{1}{2}$ -intensity points for all units:	<table border="1"> <thead> <tr> <th></th> <th>Duration*</th> <th>Energy**</th> <th>Beam Intensity†</th> </tr> </thead> <tbody> <tr> <td>at 180 fpm:</td> <td>4 μs</td> <td>0.25 Ws</td> <td>6×10^4 cd</td> </tr> <tr> <td>at 3800 fpm:</td> <td>3 μs</td> <td>0.06 Ws</td> <td>1×10^4 cd</td> </tr> </tbody> </table>				Duration*	Energy**	Beam Intensity†	at 180 fpm:	4 μ s	0.25 Ws	6×10^4 cd	at 3800 fpm:	3 μ s	0.06 Ws	1×10^4 cd
	Duration*	Energy**	Beam Intensity†												
at 180 fpm:	4 μ s	0.25 Ws	6×10^4 cd												
at 3800 fpm:	3 μ s	0.06 Ws	1×10^4 cd												
	<table border="1"> <thead> <tr> <th></th> <th>Duration*</th> <th>Energy**</th> <th>Beam Intensity†</th> </tr> </thead> <tbody> <tr> <td></td> <td>6 μs</td> <td>0.75 Ws</td> <td>30×10^4 cd</td> </tr> <tr> <td></td> <td>4 μs</td> <td>0.2 Ws</td> <td>4×10^4 cd</td> </tr> </tbody> </table>				Duration*	Energy**	Beam Intensity†		6 μ s	0.75 Ws	30×10^4 cd		4 μ s	0.2 Ws	4×10^4 cd
	Duration*	Energy**	Beam Intensity†												
	6 μ s	0.75 Ws	30×10^4 cd												
	4 μ s	0.2 Ws	4×10^4 cd												
	<p>* Measured at $\frac{1}{3}$ of peak-intensity points. ** Electrical input to lamp, watt-seconds. † Measured with silicon photo detector 1 meter from lamp, candela.</p>														
Environment: TEMPERATURE: 0 to 50°C operating, -40 to +75°C storage. HUMIDITY: 95% RH at +40°C (MIL E-16400-4.5.4.6). VIBRATION: 0.03 in. from 10 to 55 Hz. BENCH HANDLING: 4 in. or 45° (MIL-810A-VI). SHOCK: 50 g, 11 ms (MIL 202C-205C).	<p>lb (0.8 kg) net, 2 lb (0.9 kg) shipping. 1543 and 1544 DIMENSIONS (wxhxd): 4.2x6.19x7.8 in. (107x157x198 mm). WEIGHT: 3.7 lb (1.7 kg) net, 5 lb (2.3 kg) shipping.</p>														
Power: 105 to 125 V, 50 to 60 Hz, 9 W max for 1542-B, 25 W max for 1543 and 1544.	<table border="1"> <thead> <tr> <th>Description</th> <th>Catalog Number</th> </tr> </thead> <tbody> <tr> <td>1542-B Strobotac® electronic stroboscope</td> <td>1542-9701</td> </tr> <tr> <td>1543 Strobotac® electronic stroboscope</td> <td>1543-9700</td> </tr> <tr> <td>1544 Strobotac® electronic stroboscope</td> <td>1544-9700</td> </tr> </tbody> </table>			Description	Catalog Number	1542-B Strobotac® electronic stroboscope	1542-9701	1543 Strobotac® electronic stroboscope	1543-9700	1544 Strobotac® electronic stroboscope	1544-9700				
Description	Catalog Number														
1542-B Strobotac® electronic stroboscope	1542-9701														
1543 Strobotac® electronic stroboscope	1543-9700														
1544 Strobotac® electronic stroboscope	1544-9700														
Mechanical: Molded plastic case with plastic face plate to protect lamp, diffused-finish anodized-aluminum reflector, standard 0.25-20 threaded hole for tripod mounting. 1543 and 1544 also include metal stand/handle. 1542-B DIMENSIONS (wxhxd): 4.2x4.2x7.8 in. (107x107x198 mm). WEIGHT: 1.8	<p>Accessories: Replacement flash lamp for 1542-B, 1543, and 1544 1530-9410 Arm, for 1542-B, 1543, or 1544 to position light conveniently in permanent or semi-permanent installations 1544-9600</p>														

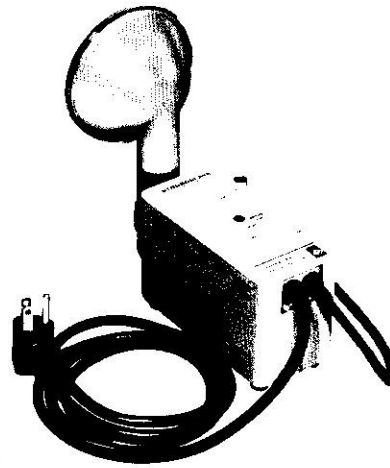
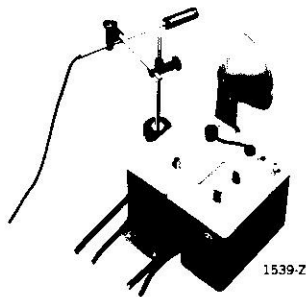

Stroboslave® stroboscopic light source 1539

- low cost, compact
- removable lamp on 5-foot cable
- high-intensity light
- choice of trigger sources

Slaved light The Stroboslave® stroboscopic light source satisfies the basic requirements for motion studies and high-speed photography — it produces a bright white light at flash rates up to 25,000 per minute. Since it contains no internal oscillator to establish the flash rate, it is an economical unit and is well suited for use with external inputs.

The lamp and reflector assembly is held in place by a clip from which it can be easily removed and positioned separately from the main unit. A five-foot flexible cable is supplied and cables up to 50 feet can be used. When

the reflector is removed from the assembly, the lamp can be inserted through holes as small as one inch in diameter, thus making it possible to observe objects in otherwise inaccessible areas.

Delayed light — the 1539-Z The Stroboslave strobe can be triggered by a contact closure or a two-volt positive pulse. This capability has proved so useful when used with the 1531-P2 Flash Delay and 1536 Photoelectric Pickoff that the Stroboslave is regularly available with these two accessories as the 1539-Z Motion-Analysis and Photography Set. The Flash Delay provides adjustable delays from 100 μ s to 800 ms from the time of the trigger to the time of the flash, so you can make the flash occur at precisely the desired moment.

SPECIFICATIONS

Flash Rate: 0 to 25,000 flashes per minute, eternally triggered only.

Light Output: Beam width is 10° at ½-intensity points.

	Duration*	Energy**	Beam Intensity†
at 700 fpm	3 μ s	0.5 Ws	11 \times 10 ⁶ cd
at 4200 fpm	1.2 μ s	0.09 Ws	3.5 \times 10 ⁶ cd
at 25,000 fpm	0.8 μ s	0.014 Ws	0.6 \times 10 ⁶ cd

* Measured at ½ of peak-intensity points.

** Electrical input to lamp, watt-seconds.

† Measured with silicon photo detector 1 meter from lamp; single-flash beam intensity is 18 \times 10⁶ candela.

External Trigger: Contact closure or pulse of \geq + 2 V pk applied to phone jack.

Supplied: Phone plug for input jack, mounting bracket, attached power cord.

Available: 1536 Photoelectric Pickoff with 1531-P2 Flash Delay (available as 1539-Z Motion Analysis and Photography Set), 1537 Photoelectric Pickoff.

Power: 100 to 125 or 195 to 250 V, 50 to 400 Hz, 16 W max.

Mechanical: Metal case with detachable lamp housing. DIMENSIONS (wxhxd): 1539-A, 2.5x8.38x4.13 in. (64x213x105 mm). WEIGHT: 1539-A, 3 lb (1.4 kg) net, 8 lb (3.7 kg) shipping; 1539-Z, 6 lb (2.8 kg) net, 17 lb (8 kg) shipping.

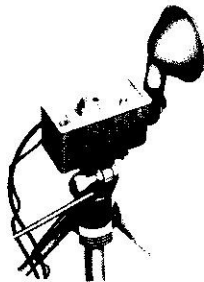

A tripod socket is provided on the Stroboslave® case.

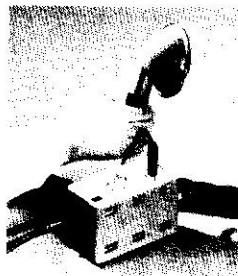

The lamp can be removed from its clamp at end of case and hand-held up to 5 feet away.

Description	Catalog Number
1539-A Stroboslave® stroboscopic light source	1539-9701
1539-Z Motion Analysis and Photography Set	
115-V Model	1539-9900
230-V Model	1539-9901
1531-P4 Trigger Cable, for use with 1531 Strobotac	1531-9604
1538-P1 Strobotron Flash Lamp, replacement	1538-9601
U.S. Patent Number 2,977,508.	

© National Stock Number 5960-00-781-1466

Strobe Accessories

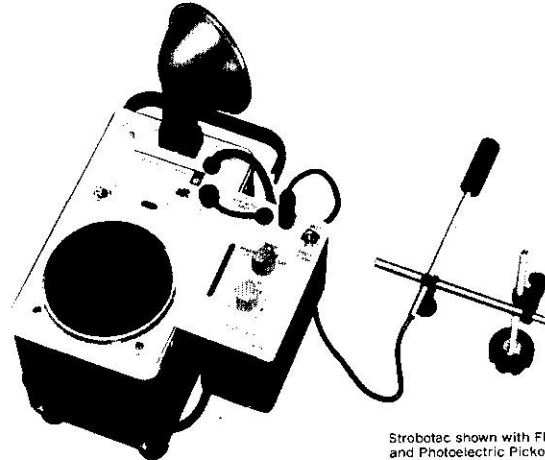

Strobotec shown with Flash Delay and Photoelectric Pickoff.

1531-P2 Flash Delay

- synchronizes and times flash
- stops motion at any point in cycle
- is easily synchronized with camera for single-flash operation
- easily attached to 1531-AB, 1538-A, and 1539-A

Valuable asset The 1531-P2 is a valuable asset to any stroboscopic or high-speed photographic application. The Flash Delay synchronizes the strobe with rapidly moving objects and controls the flash, relative to the position of the object, by introducing a variable time delay in the electrical path between the trigger source (transducer, contact, photocell, etc) and the strobe. In stroboscopic applications this delay allows you to position the stopped motion to any point of interest in the action. By the simple turn of a knob, you can reposition the image to illustrate a dozen, or even a hundred, points in order to analyze completely all aspects of the motion.

For photographic records, a single-flash mode is provided. Once the delay has been set so the image is posi-

tioned properly, the mode is set to Single Flash and the flash will then occur only when the camera shutter is released and the action is in the proper position. This mode allows the brightest possible flash and eliminates blur.

SPECIFICATIONS

Delay: 100 μ s to 800 ms in 3 ranges.

Input: 300 mV rms min applied to phone jack.

Output: +13-V pk pulse, sufficient to trigger 1531, 1538, 1539, and 1540; available at phone plug.

Supplied: Trigger cable with pushbutton, phone-plug adaptor, carrying case.

Power: 105 to 125 or 210 to 250 V, 50 to 400 Hz, 5 W max with 1536 connected.

Mechanical: Aluminum case with bracket that clips directly to 1531, 1538, or 1539 stroboscope. DIMENSIONS (wxhxd): 5.13x3.13x3.75 in. (130x79x95 mm). WEIGHT: 2 lb (1 kg) net, 5 lb (2.3 kg) shipping.

Description	Catalog Number
1531-P2 Flash Delay	
115-V Model	1531-9602
230-V Model	1531-9605

1531-P3 Surface-Speed Wheel

Surface-speed measurements simplified The 1531-P3 is used with the 1531, 1538, and 1540 (with 1540-P1 control unit) electronic stroboscopes to make accurate measurements of the linear surface speed of belts, pulleys, wheels, drums, rollers, etc. Two black nylon wheels of different diameters are mounted on the ends of a sectioned steel rod. The selected wheel is held against the moving object and the stroboscope is adjusted until the wheel's rotation appears stopped. The wheel's diameters are sized so the surface speed can be read directly from the stroboscope dial.



SPECIFICATIONS

Speed: 10 to 2500 ft/min with small wheel; 50 to 12,500 ft/min with large wheel.

Mechanical: DIMENSIONS: Wheels, 0.764 and 1.910 in. dia; shaft, 20 in. (533 mm) total length. WEIGHT: 0.5 lb (0.3 kg) net, 2 lb (1 kg) shipping.

Description	Catalog Number
1531-P3 Surface-Speed Wheel	1531-9603

Strobe Accessories (Cont'd) 1536 and 1537 Photoelectric Pickoffs

- optical trigger sources
- small, sturdy mounting
- trigger rates to 150,000 rpm

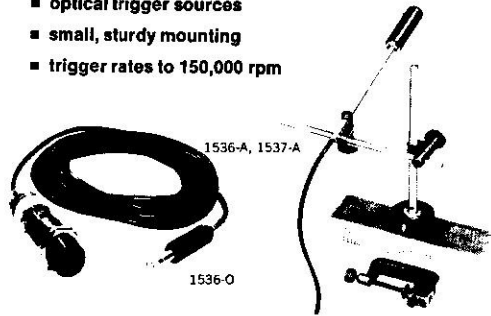

Excellent trigger source These photoelectric pickoffs produce an output whenever the photosensitive element senses a change in light such as that produced by a piece of reflective type on a moving object. The resultant pulses can be used to trigger a stroboscope so the flashes occur in synchronism with the motion, to permit the object to be viewed or photographed as though stationary. They can also be used to trigger oscilloscopes or electronic counters.

The 1536-A Pickoff, in addition to its photocell, contains a light source that can be powered directly from the 1531-P2 Flash Delay, 1540-P4 Oscillator/Delay, or 1544 Strobotac® electronic stroboscope. This pickoff's 8-ft cable is terminated with a 3-wire telephone plug.

The 1536-O pickoff is electronically identical to the 1536-A and can be used with the same equipment. They differ only in mechanical details. The 1536-O is designed to be permanently attached to a machine such as a printing press, processing equipment, etc. It is contained in a 0.75-in.-27 threaded housing to which is attached a removable 15-foot cable terminated with a 3-wire telephone plug.

The 1537-A pickoff will trigger the 1538, 1539, 1540-P1, 1540-P3, or 1540-P4 (but not the 1531) strobes. Since it lacks a built-in lamp, this pickoff must be used with an external light source. The 1537-A pickoff's 8-ft cable is terminated with a 2-wire telephone plug.

SPECIFICATIONS

	1536-A, 1536-O, with lamp	1537-A, no lamp
Rate	≈2500 pulses/s max; limited by 200- μ s time constant of cable and photocell.	>2500 pulses/s
Power	20 to 28 V dc, 40 mA; supplied by 1531-P2, 1540-P4, 1544.	3 to 25 V dc, 0 to 100 μ A depending on rate.

Supplied: 10-ft roll of 0.38-in black tape, 10-ft roll of 0.38-in silver tape, carrying case (supplied with 1536-A and 1537-A only).

Mechanical: 1536-A and 1537-A: Mounted by C clamp (1.31-in. capacity, flat or round) or 1.5-in. magnet; both supplied. **DIMENSIONS:** Pickoff head, 0.69-in. dia x 2-in. long. Linkage consists of two 0.31-in. dia stainless-steel rods, 6 and 6.25 in. long, and adjustable connecting clamp. Cable is 8 ft (2.4 m) long, terminated in 3-wire phone plug in 1536-A, a 2-wire phone plug in 1537-A. **WEIGHT:** 1.3 lb (0.6 kg) net, 4 lb (1.9 kg) shipping. **1536-O:** Mounted by 0.75-in.-27 nut. **DIMENSIONS:** 0.75-in. dia x 2.063 in. long (19 x 52 mm). Cable is 15 ft (4.6 m) long, terminated in 3-wire phone plug. **WEIGHT:** 0.4 lb (0.2 kg) net, 2 lb (1 kg) shipping.

Description	Catalog Number
1536-A Photoelectric Pickoff, with lamp	1536-9701
1536-O Photoelectric Pickoff, with lamp	1536-9702
1537-A Photoelectric Pickoff, no lamp	1537-9701

Photo Credits

page 45 — Professor Rex Nelson, Occidental College, Los Angeles, Calif.

page 63, bottom — Professor F.N.M. Brown, University of Notre Dame

page 71 — David Eldridge, Edward Skinner, and James Tsepas, Andover High School, Massachusetts

page 72 — Wyeth Laboratories, Inc.

Index

Accuracy of speed measurement	18
Air-current studies	62
Applications	43
Battery-operated stroboscope	9,87
Beam angle	9,10,39,82
Belt tension measurement	55
Bibliography	80
Calibration	24,75
Camera shutter speed calibration	69
Camera shutter synchronization	15,35,37
Catalog section	84
Cavitation studies	61
Color combination	49
Contactors	13,30,82
Digital speed indication	28
Disks, stroboscopic	48
Duration, flash	9,11,39,82
Dynamic balancing	66
Edgerton, Harold	3
Education applications	45-47,49,50,52,70,71
Electrical triggering	31
Exposure data	40
Flash delay	15,31,82,85
Flash duration	9,11,35,82
Flash intensity	9,10,11
Flashing rate calibration	24
Flicker	18,82
Flutter	73
Harmonic-relation nomographs	77
Harmonic techniques	19
High-intensity stroboscope	5,10,84
High-speed measurements	19,77
High-speed photography	3,35
High-speed stroboscope	9,87
Holdover	82
Horsepower measurement	55
Inexpensive inspection strobes	12
Intensity, flash	9,10,11
Label inspection	72
Linear speed measurement	16,23
Loudspeaker studies	46
Low-speed measurements	21
Make-break contactors	30
Medical applications	57,71,73
Meter ballistics measurements	64

Multiple-image photography	40,82
Persistence of vision	1
Photoelastic studies	74
Photoelectric pickoff	13,14,30,31,83,92
Photography, high-speed	3,15,35
Pickoff, photoelectric	13,14,30,31,83,92
Precision readouts	28
Printing applications	56
Range extension	19
Readouts, precision	28
Ripple-tank photography	70
Rpm measurement	17
Shadowgraphs	71
Shutter speed calibration	69
Shutter synchronization	15,37
Slip measurement	22,56
Slow-motion observation	29,33
Spectral characteristics	40
Speed measurement, cyclic	17
Speed measurement, linear	16,23
Speed measurement, surface	16,23
Strobolume	5,10,11,83-86
Strobolume control units	11,85,86
Stroboscope, battery-operated	9,87
Stroboscope, definition	1,83
Stroboscope, electronic	5
Stroboscope, high-intensity	5,10,84
Stroboscope, high-speed	9,87
Stroboscope, history	3
Stroboscope, principles of	1,17,29,47,48
Stroboslave	5,10,90
Strobotac	5,7,83,87-89
Strobotron	83
Subharmonic images	18
Surface speed wheels	16,17,23,83,91
Synchronization, photographic	36
Synchronizer, photoelectric	13,30
Tachometer calibration	52
Tachometer, stroboscope as	17,75
Television, closed-circuit	23
Textile applications	58,59
Torque measurement	16
Triggering requirements	31,32
Velocity measurement	67
Vibration measurement	20
Vision, persistence of	1